

BUCHER
hydraulics



Product Overview



He who knows the goal can decide;
He who decides, finds tranquillity;
He who finds tranquillity is safe;
He who is safe can consider;
He who can consider, can improve.
Konfuzius

Welcome to the World of Bucher Hydraulics...

For several decades, we have been a leading supplier of innovative solutions in hydraulic drive and control technology. With our wide technical expertise, we will smooth your way through your projects from idea to finished product. We can offer you the support you need at any stage of your technically challenging projects, whether it be in the concept phase, when setting the specification or at the start of volume production of your high quality and often future-oriented vehicles and machines. The product overview in the

next pages should give you an initial impression of our product range. Furthermore, we can offer you a variety of possible solutions for your individual requirements. Our sales representatives and distributors look forward to working together with you to find the best solutions to meet your needs.

You can find your personal contacts on our website:
www.bucherhydraulics.com



Contents

Products	Series					Page
Pumps						
		bar	cm ³ /rev	psi	in ³ /rev	
Internal Gear Pumps	QX	320	3 - 500	4 600	0.2 - 30	10
Internal Gear Pumps for Low Viscosity fluids	QXEH	250	5 - 500	3 600	0.3 - 30	11
Internal Gear Pumps	QXP	250	3 - 500	3 600	0.2 - 30	12
External Gear Pumps	AP	300	0.25 - 93	4 300	0.02 - 5.8	13+14
Motors						
		bar	cm ³ /rev	psi	in ³ /rev	
Internal Gear Drive Units	QXM	320	5 - 500	4 600	0.3 - 30	18
Internal Gear Motors	QXM-Mobil	210	2,5 - 8	3 000	0.2 - 0.5	19
Internal Gear Motors	QXM42-HS	240	20 - 32	3 400	1.2 - 2	20
Internal Gear Flow Dividers	QXT	250	5 - 250	3 600	0.3 - 15	22
External Gear Motors	APM(R)	250	8,5 - 33,0	3 600	0.39 - 2.0	23+24
Power Units						
		bar	cm ³ /rev	psi	in ³ /rev	
Hydraulic Power Packs	UP, M-series	240	0.25 - 10	3 400	0.02 - 0.6	28
Electro-hydraulic Pumps	ET	250	0.25 - 10	3 600	0.02 - 0.6	29
Cylinders						
		bar	∅ mm	psi	in	
Cylinders	various	1000	10 - 300	14 000	0.5 - 11	32+33
Directional Spool Valves						
		bar	l/min	psi	gpm	
Monoblock Construction:						
Hand operated, electro-hydraulic on/off or hydraulic proportional actuation	HDM	300	80	4 300	21	36+37
Electric, Hydraulic, Manual and Combined	MV	350	450	5 000	119	38
Manifold Mounting:						
Electric, Hydraulic, Manual and Combined	CV	350	450	5 000	119	39
Solenoid Directional Valves (CETOP)	W	350	160	5 000	42	40
Sectional Construction:						
Hand operated, electro-hydraulic direct on/off or hydraulic proportional	HDS	300	180	4 300	48	42+43
Manual, on/off and proportional solenoid with direct and pilot actuation, hydraulic actuation	L.8S	315	150	4 500	40	44
Hydraulic, Solenoid On/Off, Proportional, Electrically Operated Two-stage, On Board Electronic	LVS	350	260	5 000	69	45
Electrical, hydraulic, manual, or with onboard electronics	LVS18	350	400	5 000	105	46
Electrical, hydraulic, manual, or with onboard electronics	SC18	350	400	5 000	105	47
Electrical, hydraulic, manual, or with onboard electronics	SC22 / SVC25	350	600	5 000	158	48
Cartridge Valves						
		bar	l/min	psi	gpm	
Solenoid Directional Valves	W	420	350	6 000	92	52
Cooler-Bypass Thermostat Valves	W	50	300	700	79	53
Pressure Valves	D	450	350	6 400	92	54
Pressure Valves	U, D	500	800	7 100	211	55
Rapid Traverse Valves	EGP	350	250	5 000	66	56
Solenoid Pressure-Control Valves	D	420	350	6 000	92	57

Product	Series					Page
Flow-Control Valves	M	420	250	6 000	66	58
Check Valves	R	350	360	5 000	95	59+60
Pilot Operated Check Valves	ERV, DERV	600	100	8 600	26	61
Stack Valves		bar	l/min	psi	gpm	
Solenoid Directional Valves	SW	350	300	5 000	79	64
Pressure Valves	SD	350	300	5 000	79	65
Check Valves	SR	350	300	5 000	79	66
Flow-Control Valves	SM	350	260	5 000	69	67
Check Valves for SAE Flange Connections	RVSAE	420	1200	6 000	317	68
Safety Valves		bar	l/min	psi	gpm	
Travel Brake Valves	F, WV	420	400	6 000	105	72
Load Control Valves	CINDY	420	500	6 000	132	73
Load Control Valves redundant	CINDY-R	420	500	6 000	132	74
Regenerative Load-Control Valves	CINDY-REG	420	400	6 000	105	75
Brake Valves	BBV	420	50	6 000	13	76
Load Control Valves	REFUVA	420	300	6 000	79	77
Pipe Rupture Valves for Excavators	ESV, CFS	420	500	6 000	132	78
Pipe Rupture Valves	RS	350	500	5 000	130	79
Ex Protected Valves		bar	l/min	psi	gpm	
Valves for Potentially Explosive Areas	EEx-W	315	90	4 500	24	82
Proportional Directional Valves	various	350	600	5 000	158	83
Directional Seat Valves		bar	l/min	psi	gpm	
Monoblock and Sectional Valves	SVH04	250	20	3 600	5.3	86
Monoblock Valves	WSH03	250	25	3 600	6.6	87
Flow-Control Valves		bar	l/min	psi	gpm	
Flow Dividers	MTDA	420	250	6 000	66	90
Flow-Control Valves:						
Manually Adjustable and Fixed Adjustment	MT	315	80	4 500	21	91
Proportional Solenoid Adjustment	MVRPLSA, SR	315	100	4 500	26	92
Differential Lock Valves	MT..DV.	420	250	6 000	66	93
Mobile Electronics						
Joysticks, Controls, Amplifier and Control PCB's						96-98
System Solutions						
System Solutions (Subsystems), Fan Controls, Internal Gear Pumps for Variable Speed Drives						102-104
System Solutions for Crane Controls						106
System Solutions for Towed machines						107

Please note that the figures in the blue type are U.S. units.

Let's talk about first-class products that support protecting (y)our environment.



Environmental Issues, Health and Safety at Work in Accordance with ISO 14001 A company's excellence becomes apparent wherever sales success is not only ostensibly a determining factor. Bucher Hydraulics avow themselves to environmentally conscious production methods and are committed to complying with standard guidelines. Amongst other things this entails reducing raw material, operating supply item and water consumption, handling hazardous substances in an ecologically acceptable manner, using energy efficiently, minimizing emissions and wastage as well as exercising precautionary measures taken by their emergency management team to prevent hazards and accidents.



ECOdraulics

The more intelligent solution

Bucher Hydraulics is rising to the challenge to strive towards an ecological present and future. Like every idea, ECOdraulics starts off as a concept and continues with everyone acting in a tangible and deliberate way. Our products comply with at least one of the following criteria:

- Reduced energy consumption
- Lower emissions, such as noise or lost heat
- Protection of the environment
- Optimization through system design

High quality standards from initial development through to flexible series production in accordance with ISO 9001.





Hydraulic pumps from Bucher Hydraulics are available in both internal gear and external gear designs, suitable for medium and high pressure applications.

They are powerful yet compact, reliable yet cost effective, and together with their high efficiency, long service life and fine size increments, these are key reasons for using these pumps.

Pumps

- **Internal Gear Pumps**
 - Quiet, powerful and long-lasting
 - For low-viscosity fluids
 - For polyurethane production
- **External Gear Pumps**
 - Compact and robust

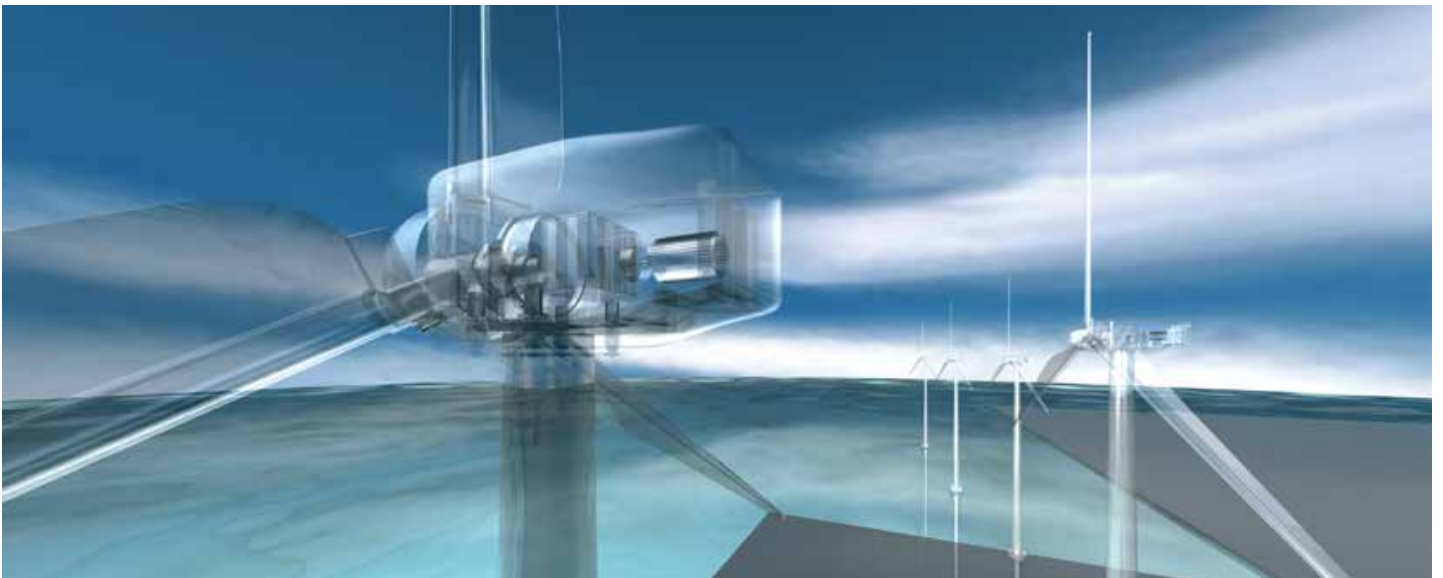

Quiet, powerful and long-lasting

QX Internal Gear Pumps



Features

- Fixed displacement pump
- For open loop systems
- **Displacement:** 3 - 500 cm³/rev
(0.2 - 30 in³/rev)
- **Maximum continuous pressure:**
 - Pressure range 1 100 - 160 bar
(1 400 - 2 300 psi)
 - Pressure range 2 210 bar (3 000 psi)
 - Pressure range 3 320 bar (4 600 psi)
- **Maximum intermittent pressure:**
 - Pressure range 1 125 - 210 bar
(1 800 - 3 000 psi)
 - Pressure range 2 250 bar (3 600 psi)
 - Pressure range 3 400 bar (5 700 psi)

Advantages

- Very high life expectancy
- Sound pressure level <57 dB(A)
- Volumetric efficiency up to 98 %
- Trouble-free operation with fire-resistant fluid such as HFB, HFC and HFD
- Suitable for use with variable speed drives

Size metric		2	3	4	5	6	8
Displacement	cm ³ /rev	3,3 - 16	10 - 31,2	20,4 - 64,7	39,3 - 127,3	80,2 - 160,5	163 - 498,5
Flow rate at 1450 min ⁻¹	l/min	4,8 - 23	14,5 - 45,2	29,5 - 93,8	56,9 - 184	116 - 362	236 - 722
Max. speed	min ⁻¹	3 600	3 400	3 200	2 800	2 300	1 800
Power requirement	kW	2,6 - 6,2	5 - 12,1	10,5 - 25	20 - 49,3	40,5 - 96,5	83 - 193
Torque	Nm	17 - 41	34 - 80	68 - 165	132 - 321	268 - 636	544 - 1270

Size imperial		2	3	4	5	6	8
Displacement	in ³ /rev	0.2 - 1	0.6 - 1.9	1.2 - 3.9	2.4 - 7.8	4.9 - 9.8	9.9 - 30.4
Flow rate at 1450 rpm	gpm	1.3 - 6	4 - 12	8 - 25	12.5 - 48.5	30.5 - 95.5	62.5 - 190.5
Max. speed	rpm	3 600	3 400	3 200	2 800	2 300	1 800
Power requirement	kW	2.5 - 6	5 - 12,1	10.5 - 25	20 - 49.5	40.5 - 96.5	83 - 193
Torque	lbf ft	13 - 30	25 - 60	50 - 120	95 - 235	200 - 470	401 - 935

Industrial model for variable-speed drives

QXEH Internal Gear Pumps

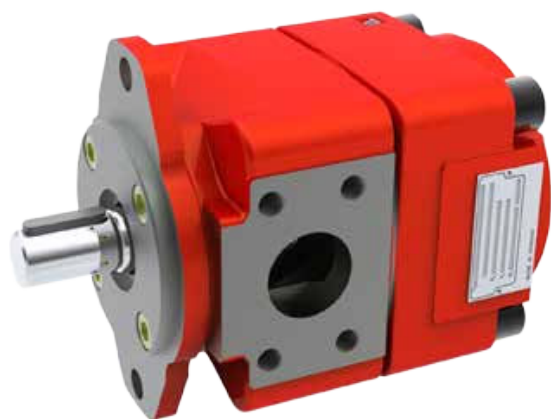

Features

- Fixed displacement pump
- Single-stage units with just one pair of gear wheels
- Displacement: 10 - 160,5 cm³/rev (0.6 - 9.8 in³/rev)
- Max. continuous pressure: 250 bar (3 600 psi)
- Max. intermittent pressure: 280 bar (4 000 psi)

Advantages

- Resists cavitation with critical fluids
- Ideally suited for use with variable-speed drives
- Maximum reliability
- Pressure and flow pulsations are minimal
- Can be used in challenging environments and with critical fluids

Size		QXEH32	QXEH42	QXEH52	QXEH62
Displacement	cm ³ /rev	10 - 15,6	20,4 - 32,4	39,3 - 63,7	80,2 - 160,2
Flow rate with 1450 min ⁻¹	l/min	14,5 - 22,6	29,5 - 46,8	56,9 - 92,1	116 - 232
Max. speed	min ⁻¹	3 800 - 4 600	3 400 - 4 000	2 800 - 3 200	2 300 - 2 700
Input power	kW	6,0 - 9,4	12,3 - 19,6	23,7 - 38,5	48,5 - 67,9
Torque	Nm	39,8 - 62,1	81,2 - 129	156,4 - 253,6	319,3 - 447

Size imperial		QXEH32	QXEH42	QXEH52	QXEH62
Displacement	in ³ /rev	0.6 - 1	1.2 - 2	2.4 - 3.9	4.9 - 9.8
Flow rate at 1450 rpm	gpm	0.4 - 6	7.8 - 12.4	15 - 24.3	30.6 - 61.3
Max. speed	rpm	3 800 - 4 600	3 400 - 4 000	2 800 - 3 200	2 300 - 2 700
Input power	kW	6,0 - 9,4	12,3 - 19,6	23,7 - 38,5	48,5 - 67,9
Torque	lbf ft	29.4 - 45.8	59.9 - 95.1	115.3 - 187	235.5 - 329.7

For low-viscosity fluids

QXV Internal Gear Pumps



Features

- Fixed displacement pump
- For open loop systems
- **Displacement:** 5 - 500 cm³/rev
(0.3 - 30 in³/rev)
- **Viscosity range:** 0.8 - 10 mm²/s (cSt)
- **Maximum continuous pressure:**

Pressure range 1	25 bar	(350 psi)
Pressure range 2	50 bar	(700 psi)
Pressure range 3	100 bar	(1 400 psi)
Pressure range 4	150 bar	(2 100 psi)
Pressure range 5	200 bar	(2 900 psi)
Pressure range 6	250 bar	(3 600 psi)

Advantages

- High operating safety
- Trouble-free operation with kerosene, diesel fuel, brake fluid, Pentosin and HFA
- Long life and low wear due to hydrodynamic bearings
- Consistent flow rate

Size metric		2	3	4	5	6	8
Displacement	cm ³ /rev	5,1 - 15,6	10 - 32,4	20,4 - 63,7	39,3 - 124,4	80,2 - 249,2	163 - 498,5
Flow rate at 1450 min ⁻¹	l/min	7.5 - 23	14.5 - 45	29.5 - 94	57 - 184	116 - 362	236 - 722
Max. speed	min ⁻¹	3 600	3 600	3 600	3 000	1 800	1 800

Size imperial		2	3	4	5	6	8
Displacement	in ³ /rev	0.3 - 1	0.6 - 2	1.2 - 3.9	2.4 - 7.6	4.9 - 15.2	9.9 - 30.4
Flow rate at 1450 rpm	gpm	2 - 6	4 - 12	8 - 25	12.5 - 48.5	30.5 - 95.5	62.5 - 190.5
Max. speed	rpm	3 600	3 600	3 600	3 000	1 800	1 800

Compact and robust

AP External Gear Pumps (Aluminium Body)



Features

- Fixed displacement pump, unidirectional and reversible types
- For open and closed loop systems
- Displacement: 0.25 - 93 cm³/rev (0.02 - 5.8 in³/rev)
- Continuous pressure (P1): up to 250 bar (3600 psi)
- Single and tandem versions
- Pump bodies aluminium made
- Cast iron front covers available
- Rear covers cast iron made with/without integrated circuits
- Reduced pressure pulsation

Advantages

- Axial pressure compensated
- Double pumps / different pump series combinations
- Integrated valves available
- Low Noise version (212LN)

Size		AP05	APR05	AP100	AP/APR212	AP/APR212LN	AP300
Displacement	cm ³ /rev	0.25 - 1.6	0.25 - 1.2	1.2 - 10	4.4 - 26.2	4.5 - 27.1	27 - 93
Max. continuous pressure (P1)	bar	170 - 190	150 - 170	150 - 210	170 - 250	170 - 250	150 - 220
Max. peak pressure (P3)	bar	180 - 230	180 - 210	200 - 280	220 - 300	220 - 300	200 - 280
Speed range	min ⁻¹	550 - 7 000	550 - 7 000	500 - 5 000	500 - 4 000	500 - 4 000	500 - 3 500

Size		AP05	APR05	AP100	AP/APR212	AP/APR212LN	AP300
Displacement	in ³ /rev	0.02 - 0.1	0.02 - 0.07	0.07 - 0.6	0.27 - 1.6	0.28 - 1.65	1.6 - 5.7
Max. continuous pressure (P1)	psi	2 400 - 2 700	2 100 - 2 400	2 100 - 3 000	2 400 - 3 600	2 400 - 3 600	2 100 - 3 100
Max. peak pressure (P3)	psi	2 600 - 3 300	2 600 - 3 000	2 900 - 4 000	3 100 - 4 300	3 100 - 4 300	2 900 - 4 000
Speed range	rpm	550 - 7 000	550 - 7 000	500 - 5 000	500 - 4 000	500 - 4 000	500 - 3 500

Heavy duty

AP External Gear Pumps (Cast Iron Body)



Features

- Fixed displacement pump, unidirectional and reversible types
- For open and closed loop systems
- Displacement: 15 - 54 cm³/rev (0.9 - 3.3 in³/rev)
- Continuous pressure: up to 300 bar (4300 psi)
- Single and tandem versions in compact design
- Complete pump cast iron made
- Integrated circuits available
- Reduced pressure pulsation
- High pressure limits

Advantages

- High volumetric efficiency
- Long life expectancy
- Low vibration / low noise
- High permissible torque between tandem/triple pumps

Size		AP212HP - APR212HP	AP212HP/LN - APR212HP/LN	AP250
Displacement	cm ³ /rev	15.1 - 33	15.7 - 34.1	15.2 - 54
Max. continuous pressure (P1)	bar	200 - 250	200 - 250	205 - 300
Max peak pressure (P3)	bar	240 - 300	240 - 300	220 - 320
Speed range	min ⁻¹	500 - 3500	500 - 3500	500 - 3500

Size		AP212HP - APR212HP	AP212HP/LN - APR212HP/LN	AP250
Displacement	in ³ /rev	0.9 - 2	1 - 2.1	0.9 - 3.3
Max. continuous pressure (P1)	psi	2900 - 3600	2900 - 3600	3000 - 4300
Max peak pressure (P3)	psi	3400 - 4300	3400 - 4300	3100 - 4600
Speed range	rpm	500 - 3500	500 - 3500	500 - 3500





Amongst their advantages, hydraulic motors from Bucher Hydraulics have a low weight-to-power ratio and are extremely compact.

The variety of types, such as internal gear, external gear and the roller-stator design, provide the best solutions for vehicles and equipment such as agricultural and forestry machinery, construction plant, municipal vehicles, industrial trucks, winches and stationary equipment. Their suitability for energy-saving drive systems is a particular benefit for many applications.

Motors

- **Internal Gear Drive Units**
All you ever wished for in a drive
- **Internal Gear Motors**
High-speed motors
- **Internal Gear Flow Dividers**
More than just a flow divider
- **External Gear Motors**
Compact and robust

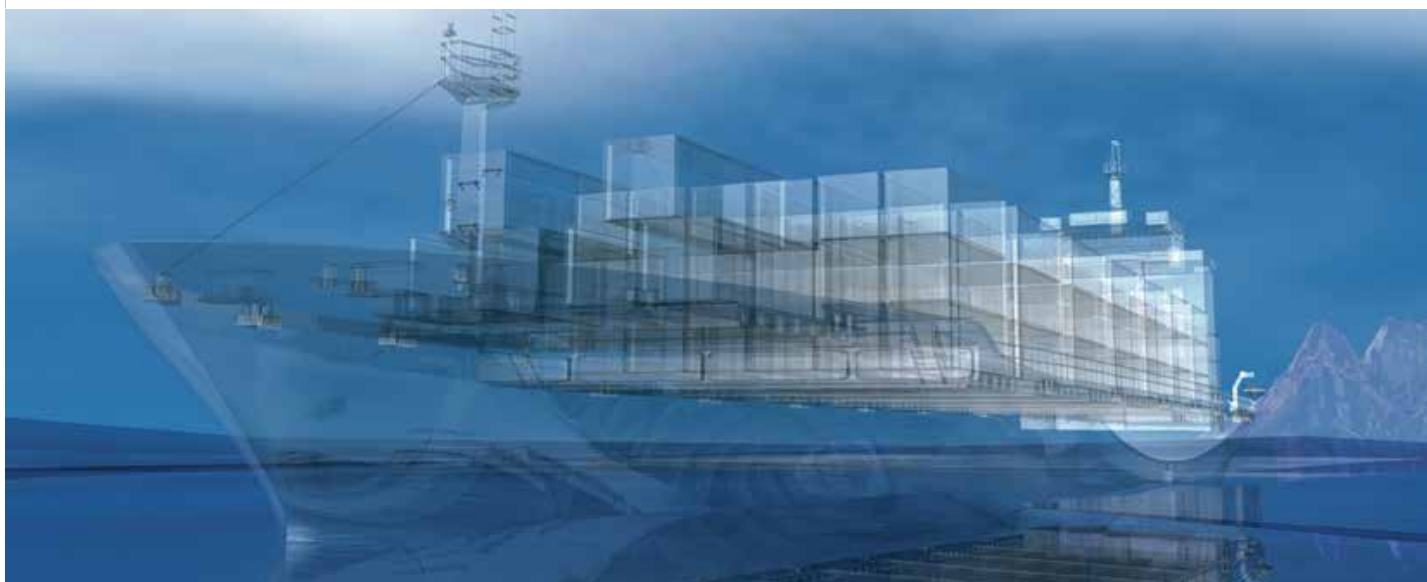

All you ever wished for in a drive

QXM Internal Gear Drive Units



Features

- Fixed displacement motor
- For open and closed loop systems
- Operates as a pump or motor with change of rotation
- Reaction rate <50 ms
- Sound pressure level <50 dB(A)

Advantages

- Reversible for one-, two- and four-quadrant operation
- Suitable for use with variable speed drives
- Over 70 % energy saving possible
- Suitable for use with fire-resistant fluids such as HFB, HFC, HFD and others

Size		2	3	4	5	6	8
Displacement	cm ³ /rev	5,1 - 15,6	10 - 32,3	20,3 - 63,5	39,2 - 124,6	80,1 - 248,8	162,7 - 498,5
Torque	Nm	17 - 41	33,5 - 80	68 - 164	131 - 323	268 - 635	544 - 1267
Max. continuous pressure	bar	320	320	320	320	320	320
Max. intermittent pressure	bar	400	400	400	400	400	400
Max. speed (pump operation)	min ⁻¹	4 000	3 200	2 900	2 500	2 250	1 600
Max. speed (motor operation)	min ⁻¹	6 000	5 500	5 000	4 500	4 000	3 500

Size		2	3	4	5	6	8
Displacement	in ³ /rev	0,3 - 1	0,6 - 2	1,2 - 3,9	2,4 - 7,6	4,9 - 15,2	9,9 - 30,4
Torque	lbf ft	13 - 30	25 - 60	50 - 121	95 - 150	195 - 470	400 - 935
Max. continuous pressure	psi	4 600	4 600	4 600	4 600	4 600	4 600
Max. intermittent pressure	psi	5 700	5 700	5 700	5 700	5 700	5 700
Max. speed (pump operation)	rpm	4 000	3 200	2 900	2 500	2 250	1 600
Max. speed (motor operation)	rpm	6 000	5 500	5 000	4 500	4 000	3 500

Designed and developed for use in mobile machines

QXM-Mobile Internal Gear Motors



Features

- Fixed-displacement motor
- Integral valve functions
- Integral outboard bearing
- Particularly suitable for fan and blower drives
- **Viscosity range:**
 - 10 - 300 mm²/s (cSt) for operation under load
 - max. 400 mm²/s (cSt) for no-load cold starts

Advantages

- Can carry very high external loads
- Extremely low leakage at the shaft seal
- Particularly suitable for high-speed operation
- First-rate starting characteristics
- Energy savings potential of up to 30 %

Size		QXM12	QXM22
Displacement	cm ³ /rev	2.5 - 4.1	5.1 - 8
Max. operating pressure	bar	210	210
Max. speed	min ⁻¹	6 000	6 000
Min. speed	min ⁻¹	100	100
Torque	Nm	8.3 - 13.4	16.7 - 26.7
Size		QXM12	QXM22
Displacement	in ³ /rev	0.2 - 0.3	0.3 - 0.5
Max. operating pressure	psi	3 000	3 000
Max. speed	rpm	6 000	6 000
Min. speed	rpm	100	100
Torque	Nm	8.3 - 13.4	16.7 - 26.7

High-speed motors

QXM42-HS Internal Gear Drive Motors



Features

- Fixed displacement motor
- For open loop systems
- External leakage connection
- Three additional connections for: Saw chain lubrication, Saw chain tension, Lubrication etc.
- Integrated valve functions
- Viscosity range 15 - 60 mm²/s (cSt) standard up to 1 000 mm²/s at zero pressure cold start
- Reaction rate <50 ms
- Sound pressure level <50 dB(A)

Advantages

- Low operating temperature
- Long service life
- Withstands extremely high radial forces
- Maximal power output
- Energy savings potential of up to 70 %

Size		42-020	42-025	42-032
Displacement	cm ³ /rev	20.3	25.1	32.3
Torque	Nm	58	70	88
Max. continuous pressure	bar	240	240	240
Max. intermittent pressure	bar	280	280	280
Min. speed	min ⁻¹	100	100	100
Max. intermittent speed	min ⁻¹	10 500	9 500	8 500

Size		42-020	42-025	42-032
Displacement	in ³ /rev	1.3	1.5	2.0
Torque	lbf ft	45	50	65
Max. continuous pressure	psi	3 400	3 400	3 400
Max. intermittent pressure	psi	4 000	4 000	4 000
Min. speed	rpm	100	100	100
Max. intermittent speed	rpm	10 500	9 500	8 500



More than just a flow divider

QXT Internal Gear Flow Dividers

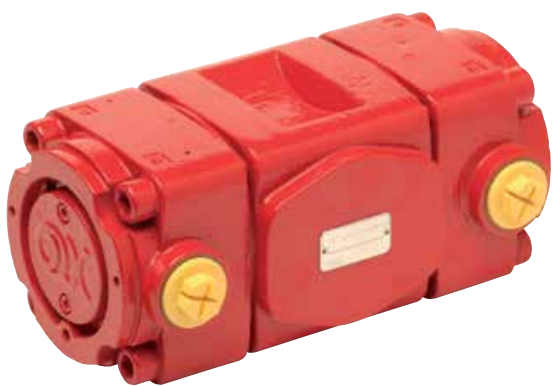

Features

- Constant ratio flow divider
- For open and closed loop systems
- Works as a pressure intensifier
- Division accuracy >98 %
- Sound pressure level <57 dB(A)
- Flow rates up to 2 000 l/min (528 gpm)

Advantages

- Long service life
- Insignificant pressure pulsations
- 2, 3 or 4 Flow Configurations available
- Exceptionally quiet operation
- Suitable for use with fire-resistant fluids such as HFB, HFC, HFD and others
- Low maintenance costs

Size		22	32	42	52	62	82
Outlet Displacement	cm ³ /rev	5 - 8	12 - 16	25 - 32	50 - 63	101 - 125	200 - 250
Max. continuous pressure	bar	250	250	250	250	250	250
Max. intermittent pressure	bar	320	320	320	320	320	320
Max. speed	min ⁻¹	6 300	5 000	4 000	3 200	2 500	2 000
Min. speed	min ⁻¹	1 250	1 000	800	630	500	400
Max. flow Q _{in} with 2 outlet flows	l/min	63 - 100	120 - 160	200 - 250	320 - 400	500 - 630	800 - 1 000
Max. flow Q _{in} with 3 outlet flows	l/min	95 - 150	180 - 240	300 - 380	480 - 600	750 - 950	1 200 - 1 500
Max. flow Q _{in} with 4 outlet flows	l/min	125 - 200	240 - 320	400 - 500	640 - 800	1 000 - 1 260	1 600 - 2 000
Outlet Displacement	in ³ /rev	0.3 - 0.5	0.7 - 1	1.5 - 2	3.1 - 3.8	6.0 - 7.6	12.2 - 15.3
Max. continuous pressure	bar	250	250	250	250	250	250
Max. intermittent pressure	bar	320	320	320	320	320	320
Max. speed	rpm	6 300	5 000	4 000	3 200	2 500	2 000
Min. speed	rpm	1 250	1 000	800	630	500	400
Max. flow Q _{in} with 2 outlet flows	l/min	63 - 100	120 - 160	200 - 250	320 - 400	500 - 630	800 - 1 000
Max. flow Q _{in} with 3 outlet flows	l/min	95 - 150	180 - 240	300 - 380	480 - 600	750 - 950	1 200 - 1 500
Max. flow Q _{in} with 4 outlet flows	l/min	125 - 200	240 - 320	400 - 500	640 - 800	1 000 - 1 260	1 600 - 2 000

Compact and robust construction

APM External Gear Motors (Aluminium Body)

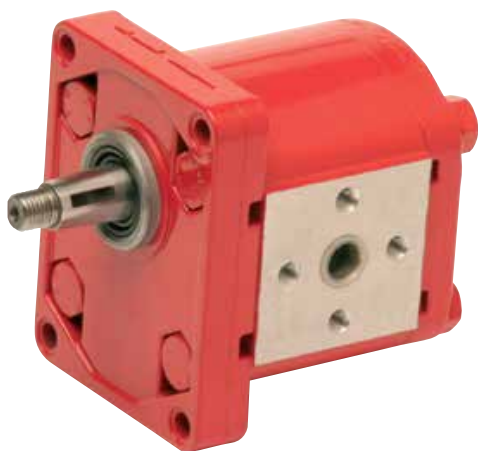

Features

- Fixed displacement motor - unidirectional and reversible
- For open and closed loop systems
- Motor bodies aluminium made
- Cast iron front covers available
- Rear covers cast iron made with/without integrated circuits
- High volumetric efficiency

Advantages

- Axial pressure compensation
- APMR reversible motors available for 2- and 4-quadrant operation
- Integrated valves available
- APM motors specially designed for cooling system fan-drive applications
- Optional external bearing attachment for extreme load applications
- Low Noise version (212LN)

APM Standard version		APM212	APM212LN		APM212	APM212LN
Displacement	cm ³ /rev	8.4 - 26.2	8.7 - 27.1	in ³ /rev	0.51 - 1.6	0.53 - 1.65
Max. continuous pressure (P1)	bar	200 - 250	200 - 250	psi	2 900 - 3 600	2 900 - 3 600
Max. peak pressure (P3)	bar	210 - 300	210 - 300	psi	3 000 - 4 300	3 000 - 4 300
Speed range	min ⁻¹	500 - 4 000	500 - 4 000	rpm	500 - 4 000	500 - 4 000
APMR Reversible version		APMR212	APMR212LN		APMR212	APMR212LN
Displacement	cm ³ /rev	8.4 - 26.2	8.7 - 27.1	in ³ /rev	0.51 - 1.6	0.53 - 1.65
Max. continuous pressure (P1)	bar	200 - 250	200 - 250	psi	2 900 - 3 600	2 900 - 3 600
Max. peak pressure (P3)	bar	210 - 300	210 - 300	psi	3 000 - 4 300	3 000 - 4 300
Speed range	min ⁻¹	500 - 4 000	500 - 4 000	rpm	500 - 4 000	500 - 4 000
APM Fan-drive version		APM212 · APMR212	APM212LN · APMR212LN		APM212 · APMR212	APM212LN · APMR212LN
Displacement	cm ³ /rev	8.4 - 26.2	8.7 - 27.1	in ³ /rev	0.51 - 1.6	0.53 - 1.65
Max. continuous pressure (P1)	bar	200 - 250	200 - 250	psi	2 900 - 3 600	2 900 - 3 600
Max. peak pressure (P3)	bar	210 - 300	210 - 300	psi	3 000 - 4 300	3 000 - 4 300
Speed range	min ⁻¹	500 - 4 000	500 - 4 000	rpm	500 - 4 000	500 - 4 000

Heavy duty and high efficiencies

APM External Gear Motors (Cast Iron Body)



Features

- Fixed displacement motor - unidirectional and reversible
- For open and closed loop systems
- Complete motor cast iron made
- Integrated circuits available
- Reduced pressure pulsation
- High pressure limits

Advantages

- Axial pressure compensation
- High volumetric efficiency
- APM motors specially designed for cooling system fan-drive applications
- Integrated valves available
- Low Noise version (212HP/LN)
- Optional external bearing attachment for extreme load applications

APM Standard version		APM212HP	APM212HP/LN		APM212HP	APM212HPLN
Displacement	cm ³ /rev	15.1 - 33.0	15.7 - 34.1	in ³ /rev	0.92 - 2.0	0.96 - 2.1
Max. continuous pressure (P1)	bar	200 - 250	200 - 250	psi	2 900 - 3 600	2 900 - 3 600
Max. peak pressure (P3)	bar	230 - 300	230 - 300	psi	3 300 - 4 300	3 300 - 4 300
Speed range	min ⁻¹	500 - 3 500	500 - 3 500	rpm	500 - 3 500	500 - 3 500
APMR Reversible version		APMR212HP	APMR212HP/LN		APMR212HP	APMR212HP/LN
Displacement	cm ³ /rev	15.1 - 33.0	15.7 - 34.1	in ³ /rev	0.92 - 2.0	0.96 - 2.1
Max. continuous pressure (P1)	bar	200 - 250	200 - 250	psi	2 900 - 3 600	2 900 - 3 600
Max. peak pressure (P3)	bar	230 - 300	230 - 300	psi	3 300 - 4 300	3 300 - 4 300
Speed range	min ⁻¹	500 - 3 500	500 - 3 500	rpm	500 - 3 500	500 - 3 500
APM Fan-drive version		APM212HP · APMR212HP APM212LN · APMR212LN			APM212 · APMR212 APM212LN · APMR212LN	
Displacement	cm ³ /rev	8.4 - 26.2		8.7 - 27.1	in ³ /rev	0.51 - 1.6
Max. continuous pressure (P1)	bar	200 - 250		200 - 250	psi	2 900 - 3 600
Max. peak pressure (P3)	bar	210 - 300		210 - 300	psi	3 000 - 4 300
Speed range	min ⁻¹	500 - 4 000		500 - 4 000	rpm	500 - 4 000





The UP range of power units are compact assemblies consisting of gear pump, electric motor valve block and oil tank.

The wide variety of configurations and the simplicity of installation have made these power units highly popular in the vehicle and handling industries. They are predominantly used for lifting and lowering functions.

Power Units

- **Hydraulic Power Packs**
Compact and powerful
- **Electro-hydraulic Pumps**
Motor-pump combination



Compact and powerful

Hydraulic Power Packs



Features

- Available with steel or plastic oil tank
- Components such as check valves, pressure relief valves, emergency release valves, flow control valves, direct or pilot-operated directional control valves, manual valves and emergency hand pumps can be integrated
- Customized systems to meet your specifications

Advantages

- Application-related assembly
- Reduced stock level
- Powerful combination
- Integrated valves
- Easy installation

Model		UP50	UP100	UP110	M-series	
Max. intermittent pressure	bar	180 - 230	180 - 230	180 - 230	240	
Flow rate	cm ³ /rev	0.25 - 2.3	0.85 - 10	0.85 - 10	0.36 - 4.18	
Tank capacity	l	0.5 - 4	1.5 - 18	1.5 - 14	0.5 - 23	
Viscosity range	mm ² /s (cSt)	20 - 120	20 - 120	20 - 120	20 - 77	
Fluid temperature range	°C	-15 to +80	-15 to +80	-15 to +80	-30 to +55	
DC motor	12...24/48 V	kW	0.35 - 2.5	0.7 - 3	1.6 - 3	0.8 - 4.5
AC motor	220/240 V	kW	0.12 - 0.75	0.25 - 2.2	0.25 - 2.2	0.5 - 2.2
	380 V	kW	0.12 - 0.75	0.25 - 4	0.25 - 4	-
Max. intermittent pressure	psi	2 600 - 3 300	2 600 - 3 300	2 600 - 3 300	3 400	
Flow rate	in ³ /rev	0.02 - 0.14	0.05 - 0.6	0.05 - 0.6	0.02 - 0.26	
Tank capacity	gal	0.13 - 1.06	0.4 - 4.8	0.4 - 3.7	0.13 - 6.08	
Viscosity range	cSt	20 - 120	20 - 120	20 - 120	20 - 77	
Fluid temperature range	°F	+5 to +176	+5 to +176	+5 to +176	-22 to +130	
DC motor	12...24/48 V	kW	0.35 - 2.5	0.7 - 3	1.6 - 3	0.8 - 4.5
AC motor	220/240 V	kW	0.12 - 0.75	0.25 - 2.2	0.25 - 2.2	0.5 - 2.2
	380 V	kW	0.12 - 0.75	0.25 - 4	0.25 - 4	-

Motor-pump combination

ET Electro-Hydraulic Pumps



Features

- Hydraulic connections by pipe flanges or threaded ports
- Available with all external gear pumps in AP05 and AP100 ranges

Advantages

- Compact unit
- Powerful

Model		ET		ET
Max. intermittent pressure	bar	250	psi	3 600
Flow rate	cm ³ /rev	0.25 - 10	in ³ /rev	0.02 - 0.6
Viscosity range	mm ² /s (cSt)	20 - 120	cSt	20 - 120
Fluid temperature range	°C	-15 to +80	°F	+5 to +176
DC motor	V	12, 24 and 48	V	12, 24 and 48
Power	kW	0.35 - 4.5	kW	0.35 - 4.5
Special functions		integrated pressure relief valve for AP100 only		



As an experienced and competent partner in the development and manufacturing of high quality cylinders Bucher Hydraulics knows from decades of experience the heavy use of mobile and industrial hydraulics. We provide convincing technical solutions for many different applications. With all our cylinders we emphasize high-tightness and reliability, persistency and minimal maintenance.

Cylinders

- **Cylinders for Mobile Hydraulics**
used in harsh environments
- **Cylinders for Industrial Hydraulics**
with high cost effectiveness



For use in harsh environments

Cylinders



Product Range

- Boom Cylinder
- Axle Locking Cylinder
- Stabilizer Cylinder
- Dozer Blade Cylinder
- Suspension Cylinder
- Counterweight Cylinder
- Locking Cylinder
- Steering Cylinder
- Brake Cylinder
- Spring Actuator
- Lift / Tilt Cylinder
- Gripper Cylinder
- Cylinder for quick hitch
- Counterbalance Cylinder
- Dosing Unit
- Cylinder for Tool Changer

Advantages

- High safety against leakage
- Consistent, temperature independent gentle damping
- Visually appealing and robust construction
- Weight reduced versions

Cylinders

Diameter piston	mm	10 - 300
Diameter rod	mm	10 - 300
Max. Stroke	mm	3 000
Max. operating pressure	bar	1 000



Features

Bucher Hydraulics offer a special and application-oriented and customized range of cylinders in a multitude of designs:

- Single- and double-acting cylinder
- Integrated valve technology and distance measurement
- Integrated nitrogen storage in the rod
- Gentle end position damping
- Induction hardened piston rod, hard chromium plated or nickel-chromium coated

- Made for cryogenic temperature
- Long service life of bearings
- High profitability

Cylinders

Diameter piston	in	0.5 - 11
Diameter rod	in	0.5 - 11
Max. Stroke	in	118
Max. operating pressure	psi	14 000



Directional spool valves are used in control and safety roles in the operating and travel hydraulics of mobile plant and machinery. There are different designs and functions such as pressure compensators, pressure limiters, check, relief and flow valves to suit all requirements.

All the valve ranges employ a building block concept. The individual elements can be put together flexibly in a valve block, according to the requirements of the application.

Directional Spool Valves

- **Monoblock Construction**
Compact
- **Manifold Mounting**
Service-friendly, standardised and reliable
- **Sectional Construction**
Modular building blocks for complex control tasks



Compact

HDM Monoblock Directional Control Valves



Features

- Monoblock construction
- For series or parallel operation
- Open centre, closed centre and carry-over circuits
- Option for integrated anti-shock, anti-cavitation, pressure relief, flow control and check valves
- Single lever actuation for 2 sections and remote cable controls
- Dedicated spool for specific applications
- Expandable with manual/electrical controlled sections (HDS15)

Advantages

- Application-oriented features
- Minimal maintenance
- Compact overall dimensions
- Fine metering spools

Size		140	11P	11S	11S/3PQ	11S/4PQ	18	15/2
Number of spools		1	2 - 6	1 - 6	3	4	1 - 4	2 - 10
Max. inlet pressure (P)	bar	250	250	250	250	250	300	250
Max. work port pressure (A/B)	bar	320	320	320	320	320	350	320
Max. return pressure	bar	30	30	30	30	30	30	20 (on-off); 30 (std); 10 (EHO)
Max. flow rate	l/min	40	45	45	50	50	70	60
Viscosity range		15 - 75 mm ² /s (cSt), Hydraulic fluid temperature -20 to +80 °C						
Actuation		Hand operated, electro-hydraulic on/off or hydraulic proportional actuation						
Size		140	11P	11S	11S/3PQ	11S/4PQ	18	15/2
Number of spools		1	2 - 6	1 - 6	3	4	1 - 4	2 - 10
Max. inlet pressure (P)	psi	3 600	3 600	3 600	3 600	3 600	4 300	3 600
Max. work port pressure (A/B)	psi	4 600	4 600	4 600	4 600	4 600	5 000	4 600
Max. return pressure	psi	430	430	430	430	430	430	290 (on-off); 430 (std); 145 (EHO)
Max. flow rate	gpm	11	12	12	14	14	19	15
Viscosity range		15 - 75 cSt, Hydraulic fluid temperature -4 to +176 °F						
Actuation		Hand operated, electro-hydraulic on/off or hydraulic proportional actuation						

Specifically designed for compact wheel loaders

HDM19 Wheel Loaders Directional Control Valves



Features

- Monoblock construction (three-spool)
- Expandable up to seven stackable sections (HDS15)
- Electro-hydraulic open loop proportional or ON-OFF controls EHO with internal pilot lines (EH)
- Wide range of fine-metering spools optimised for specific machine functions
- Manual controls with extremely low operating forces
- Wide range of controls: single and cross lever, hydraulic proportional and open loop electro-hydraulic proportional
- Manual/hydraulic joystick for controlling two functions simultaneously
- Regenerative circuit for fast dumping speed

Advantages

- Compact dimensions
- Work ports with integral flow restrictors for maximum dumping-speed setting
- Precise and stable control in each working condition
- Optional circuit to eliminate „no-reaction time“ after fast boom lowering

Size		HDM19WL	HDM19EH
Number of spools		3-10	3
Max. inlet pressure (P)	bar	250	290
Max. work port pressure (A/B)	bar	320	320
Max. return pressure	bar	30 (std) 10 (EHO)	30 (std); 10 (EHO)
Max. flow rate	l/min	80	80
Viscosity range	mm ² /s, (cSt)	15 - 75	15 - 75
Temperature	°C	-20 to +80	-20 to +80
Size		HDM19WL	HDM19EH
Number of spools		3-10	3
Max. inlet pressure (P)	psi	3 600	4 100
Max. work port pressure (A/B)	psi	4 600	4 600
Max. return pressure	psi	430 (std) 145 (EHO)	430 (std); 145 (EHO)
Max. flow rate	gpm	21	21
Viscosity range	cSt	15 - 75	15 - 75
Temperature	°F	-4 to +176	-4 to +176

Compact

MV Proportional Directional Valve Systems

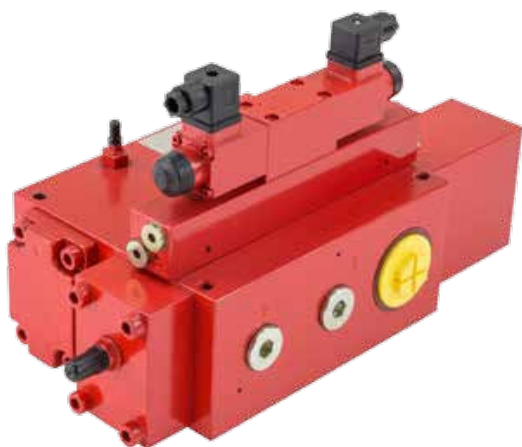

Features

- Monoblock construction
- Internal load feedback
- 2- or 3-way pressure compensation
- Individual adjustment of flow rates
- All valve functions are integrated in a single compact block
- Up to four proportional directional valve functions
- Primary pressure relief can be included

Advantages

- Sensitivity and precision of load control
- Load-independent flow adjustment
- Specially developed for use in mobile hydraulics
- Perfectly matched to the application

Size		12	18	25
Max. operating pressure	bar	350	350	350
Max. return pressure	bar	50	50	50
Max. flow rate	l/min	100	200	450
Viscosity range	mm ² /s (cSt)	10 - 380		
Hydraulic fluid temperature	°C	-20 to +80		
Voltage	V	12 or 24 DC		
Type of actuation		Electric, hydraulic, manual, Ex protection and combinations of these		
Size		12	18	25
Max. operating pressure	psi	5 000	5 000	5 000
Max. return pressure	psi	700	700	700
Max. flow rate	gpm	26	53	119
Viscosity range	cSt	10 - 380		
Hydraulic fluid temperature	°F	-4 to +176		
Voltage	V	12 or 24 DC		
Type of actuation		Electric, hydraulic, manual, Ex protection and combinations of these		

Service-friendly and reliable

CV Proportional Directional Valve Systems

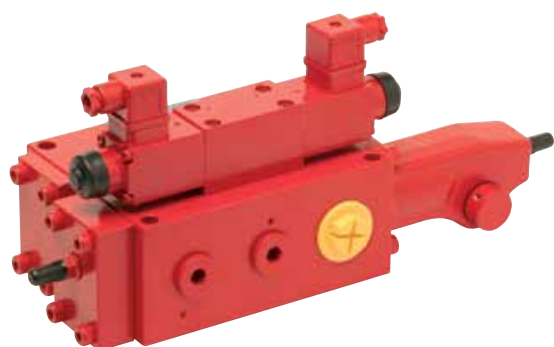

Features

- Compact manifold mounting design
- Internal load feedback
- 2- or 3-way pressure compensation
- Individual adjustment of flow rates
- Primary pressure relief can be included
- All valve functions are integrated in a single compact block

Advantages

- Load-independent flow adjustment
- Sensitivity and precision of load control
- Perfect match to the application
- Easy maintenance due to quick-change of individual components means minimum service interruption

Size		12	18	25
Max. operating pressure	bar	350	350	350
Max. return pressure	bar	50	50	50
Max. flow rate	l/min	100	200	450
Viscosity range	mm ² /s (cSt)		10 - 380	
Hydraulic fluid temperature	°C		-20 to +80	
Voltage	V		12 or 24 DC	
Type of actuation		Electric, hydraulic, manual, Ex protection and combinations of these		
Size		12	18	25
Max. operating pressure	psi	5 000	5 000	5 000
Max. return pressure	psi	700	700	700
Max. flow rate	gpm	26	53	119
Viscosity range	cSt		10 - 380	
Hydraulic fluid temperature	°F		-4 to +176	
Voltage	V		12 or 24 DC	
Type of actuation		Electric, hydraulic, manual, Ex protection and combinations of these		

Standardised and reliable

Directional Solenoid Valves, Manifold Mounting (CETOP)

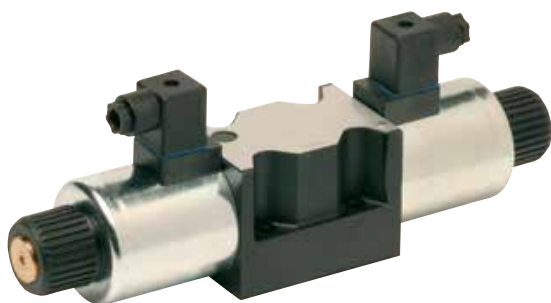

Features

- **Mounting pattern:**
 - ISO 4401-02-01 NG4
 - ISO 4401-03-02 NG6
 - ISO 4401-05-04 NG10
 - CETOP R35H 03, 05
 - DIN 24340 A6
 - DIN 24340 A10
 - NFPA D03, D05
- Direct acting seat valve
- Direct acting and two-stage spool valves

Advantages

- Available in explosion-protected versions
- Unaffected by asymmetric flow, high viscosities or high pressure differentials

Size		4	6	10
Max. operating pressure	bar	250	350	315
Max. flow rate	l/min	25	100	160
Viscosity range	mm ² /s (cSt)	10 - 500	10 - 500	10 - 500
Hydraulic fluid temperature	°C	-25 to +80	-25 to +80	-25 to +80
Voltage	V	12, 24 DC / 115, 230 AC	12, 24 DC / 115, 230 AC	12, 24 DC / 115, 230 AC
Type of actuation		On/off solenoid, proportional solenoid, EEx solenoid, lever		
Protection class		IP65 (EN 60 529) for on/of and proportional solenoids; IP65 / IP67 for Ex solenoids		
Size		4	6	10
Max. operating pressure	psi	3 600	5 000	4 500
Max. flow rate	gpm	6.6	26	42
Viscosity range	cSt	10 - 500	10 - 500	10 - 500
Hydraulic fluid temperature	°F	-13 to +176	-13 to +176	-13 to +176
Voltage	V	12, 24 DC / 115, 230 AC	12, 24 DC / 115, 230 AC	12, 24 DC / 115, 230 AC
Type of actuation		On/off solenoid, proportional solenoid, EEx solenoid, lever		
Protection class		IP65 (EN 60 529) for on/of and proportional solenoids; IP65 / IP67 for Ex solenoids		

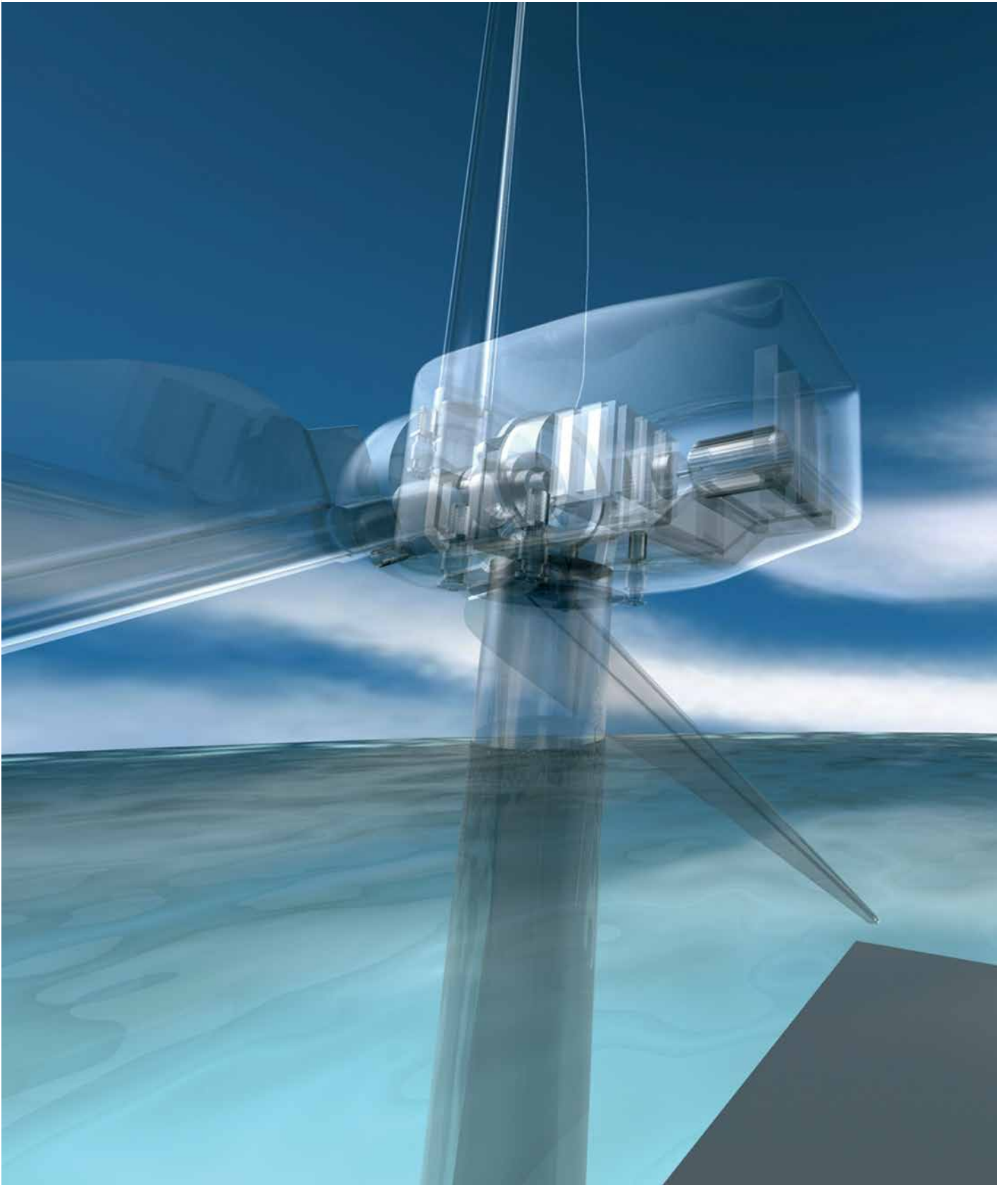

Reliable and flexible

HDS Sectional Directional Control Valves



Features

- Sectional construction, manual and electrical controls
- For series or parallel operation
- Open centre, closed centre and carry-over circuits
- Option for integrated anti-shock, anti-cavitation, pressure relief, flow control and check valves
- Single lever actuation for 2 valves and remote cable controls
- Electro-hydraulic open loop proportional/ ON-OFF controls (EHO) or electro-hydraulic closed loop proportional controls (EHC)

Advantages

- Different types of actuation may be combined
- Minimal maintenance
- Customer specific features for maximum flexibility
- Fine metering spools

Size		07 ON-OFF	11 (11 ON-OFF)	15 (15 ON-OFF)	21	30
Number of spools		1 - 10	1 - 10	1 - 10	1 - 10	1 - 10
Max. inlet pressure (P)	bar	250	250	250	290	250
Max. work port pressure (A/B)	bar	320	320	320	320	320
Max. return pressure	bar	20	30 (20)	30 (20)	30 (std); 10 (EHO)	30
Max. flow rate	l/min	25	45	60	80	120
Viscosity range	mm ² /s	15 - 75	15 - 75 (20 - 50)	15 - 75 (20 - 50)	15 - 75	15 - 75
Hydraulic fluid temperature	°C	-20 to +80				
Actuation		Hand operated, electro-hydraulic direct on/off or hydraulic proportional				
Number of spools		1 - 10	1 - 10	1 - 10	1 - 10	1 - 10
Max. inlet pressure (P)	psi	3 600	3 600	3 600	4 100	3 600
Max. work port pressure (A/B)	psi	4 600	4 600	4 600	4 600	4 600
Max. return pressure	psi	285	430 (285)	430 (285)	430 (std); 145 (EHO)	430
Max. flow rate	gpm	6.6	12	16	21	32
Viscosity range	cSt	15 - 75	15 - 75 (20 - 50)	15 - 75 (20 - 50)	15 - 75	15 - 75
Hydraulic fluid temperature	°F	-4 to +176				
Actuation		Hand operated, electro-hydraulic direct on/off or hydraulic proportional				

Superior control in a compact design

HDS24 / HDS34 Proportional Flow Sharing Directional Control Valves



Features

- Sectional design
- Downstream pressure compensation
- Fully interchangeable function-oriented spools
- Wide range of controls: single and cross lever, hydraulic proportional, open and closed loop electro-hydraulic proportional
- Easily configurable for fixed- or variable displacement pumps
- Inlet section with priority for steering
- Application-specific options for wheel loaders, telehandlers, forest equipment, backhoe loaders and excavators

Advantages

- Compact dimensions
- Precise and stable control of simultaneous operations
- Higher efficiency and reduced energy consumption
- Flexibility to satisfy a wide range of applications

Size		HDS24	HDS34		HDS24	HDS34
Number of spools		1 - 10	1 - 10		1 - 10	1 - 10
Max. inlet pressure (P)	bar	280	300	psi	4 000	4 300
Max. work port pressure (A/B)	bar	320	350	psi	4 600	5 000
Max. return pressure	bar	30 (std); 5 (EHO)	30 (std); 5 (EHO)	psi	430 (std); 70 (EHO)	430 (std); 70 (EHO)
Max. flow rate	l/min	130	180	gpm	35	48
Viscosity range	mm ² /s (cSt)	15 - 75		cSt	15 - 75	
Hydraulic fluid temperature	°C	-20 to +80		°F	-4 to +176	
Actuation		Hand operated, electro-hydraulic direct on/off or hydraulic proportional				

Modular building blocks for complex control tasks

L.8S Proportional Directional Valves



Features

- Sectional design
- Flexible system, specially developed for use in mobile hydraulics
- Additional functions can be incorporated in the modular system:
 - Two- and three-way pressure compensation
 - Priority pressure compensation
 - Individual pressure compensation
 - Check valves, load control valves
 - Relief valves
 - Anti-cavitation valves
 - Flow cut-off
 - Flow limiters
 - Manual override

Advantages

- Load-sensing capability
- Suitable with all pump types and in systems with variable feeds
- Load-independent flow adjustment even in parallel operation with multiple consumers
- Complete solution with high functionality

Model		L.8S		L.8S
Max. operating pressure	bar	315	gpm	4 500
Max. flow rate	l/min	150	gpm	40
Max. flow rate ports A + B	l/min	90	gpm	24
Max. return pressure	bar	40 (200)	psi	570 (2 900)
Viscosity range	mm ² /s (cSt)	10 - 380	cSt	10 - 380
Hydraulic fluid temperature	°C	-20 to +80	°F	-4 to +176
Voltage	V	12 or 24 DC	V	12 or 24 DC
Power consumption	W	27	hp	0.036
Type of actuation	Manual, on/off and proportional solenoid with direct and pilot actuation, hydraulic actuation			

Forward-looking technology

LVS Proportional Directional Valves



Features

- Sectional design
- Proportional flow-control functions, downstream pressure compensation, relief valve, make-up function, seat valve, manual override, two- and three-way pressure compensation, internal and external priority functions
- Available with specific operations for agricultural machinery, forestry equipment, construction machines, loading cranes and many other applications
- Proportional flow reduction at all actuators in the under-supply mode

Advantages

- Available within 4 weeks from receipt of order
- Increased handling capacity
- Lasting cost savings and increased machine performance data
- Fatigue-free operation
- Can be configured for both fixed and variable displacement pumps

Model		LVS08	LVS12		LVS08	LVS12
Max. operating pressure	bar	250	350	psi	3 600	5 000
Max. flow rate	l/min	260	260	gpm	69	69
Max. flow rate ports A + B	l/min	50	180	gpm	13	48
Max. return pressure	bar	200	50 (200 optional)	psi	2 900	700 (2 900 optional)
Viscosity range	mm ² /s (cSt)	10 to 380	10 to 380	cSt	10 to 380	10 to 380
Hydraulic fluid temperature	°C	-20 to +80	-20 to +80	°F	-4 to +176	-4 to +176
Voltage	V	12 or 24 DC	12 or 24	V	12 or 24 DC	12 or 24 DC
Power consumption	W	30	18	hp	0.040	0.024
Type of actuation		On/off and proportional solenoid with direct actuation	Manual operation, two-stage electro-hydraulic and hydraulic actuated, digital pilot head with on-board electronics		On/off and proportional solenoid with direct actuation	Manual operation, two-stage electro-hydraulic and hydraulic actuated, digital pilot head with on-board electronics

With downstream pressure compensator

Proportional Directional Valves, LVS18



Features

- Sectional design
- Proportional flow control functions, downstream pressure compensator, anti-shock valves, make-up function, seat valves, manual override, two- and three-way pressure compensators, external and internal priority function
- Flow-control function in one valve
- Application-specific functions for mobile cranes, forestry equipment, construction machines, etc.

Advantages

- Higher throughput
- Sustained cost savings and increases in machine performance ratings
- Gentle handling
- Can be configured for fixed- or variable-displacement pumps

Type		LVS18		LVS18
Max. operating pressure	bar	350	psi	5 000
Nominal pressure	bar	420 (consumer)	psi	6 000 (consumer)
Max. flow rate	l/min	400	gpm	105
Actuator flow at A and B, max.	l/min	260	gpm	69
Max. return line pressure	bar	50	psi	700
Viscosity range	mm ² /s	10 - 380	cSt	10 - 380
Hydraulic fluid temperature	°C	-20 to +80	°F	-4 to +176
Voltage	V	12 or 24 DC	V	12 or 24 DC
Type of actuation		Electrical, hydraulic, manual, or with onboard electronics		

Modular building blocks for complex control tasks

SC18 Proportional Directional Valves



Features

- Compact sectional design
- Adaptable modular system
- Individual adjustment of the flow rate up to 260 l/min per actuator
- Max. pump flow rate 400 l/min
- Individual pressure compensator
- Individual supply cut-off for each actuator port
- Optional anti-shock valves, make-up valves, or a combination
- Available with manual operation
- Threaded ports or flanged ports

Advantages

- Can be used with all types of pumps and in systems with changeable supply sources
- Responsive and accurate control of the load
- Load-independent flow control, even with parallel operation of several actuators
- Adaptable modules, specifically designed for use in mobile hydraulics

Model		SC18		SC18
Max. operating pressure	bar	350	psi	5 000
Nominal pressure	bar	420 (consumer)	psi	6 000 (consumer)
Max. flow rate	l/min	400	gpm	105
Actuator flow at A and B, max.	l/min	260	gpm	69
Max. return line pressure	bar	50	psi	700
Viscosity range	mm ² /s	10 - 380	cSt	10 - 380
Hydraulic fluid temperature	°C	-20 to +80	°F	-4 to +176
Voltage	V	12 or 24 DC	V	12 or 24 DC
Type of actuation		Electrical, hydraulic, manual, or with onboard electronics		

Modular building blocks for complex control tasks

Proportional Directional Valves SC22 / SVC25



Features

- Compact sectional design
- Adaptable modular system
- Individual adjustment of the flow rate up to 600 l/min per actuator
- Individual pressure compensator
- Individual supply cut-off for each actuator port
- Optional anti-shock valves, make-up valves, or a combination
- Available with manual operation
- Threaded ports or flanged ports

Advantages

- Can be used with all types of pumps and in systems with changeable supply sources
- Responsive and accurate control of the load
- Load-independent flow control, even with parallel operation of several actuators
- Adaptable modules, specifically designed for use in mobile hydraulics

Model		SC22	SVC25		22	25
Max. operating pressure	bar	350	350	psi	5 000	5 000
Nominal pressure	bar	420 (consumer)	420 (consumer)	psi	6 000 (consumer)	6 000 (consumer)
Max. flow rate	l/min	400	600	gpm	105	158
Max. return pressure	bar	50	50	psi	700	700
Viscosity range	mm ² /s	10 - 380	10 - 380	cSt	10 - 380	10 - 380
Hydraulic fluid temperature	°C	-20 bis +80	-20 bis +80	°F	-4 to +176	-4 to +176
Voltage	V	12 oder 24 DC	12 oder 24 DC	V	12 or 24 DC	12 or 24 DC
Type of actuation		Electrical, hydraulic, manual, or with onboard electronics				

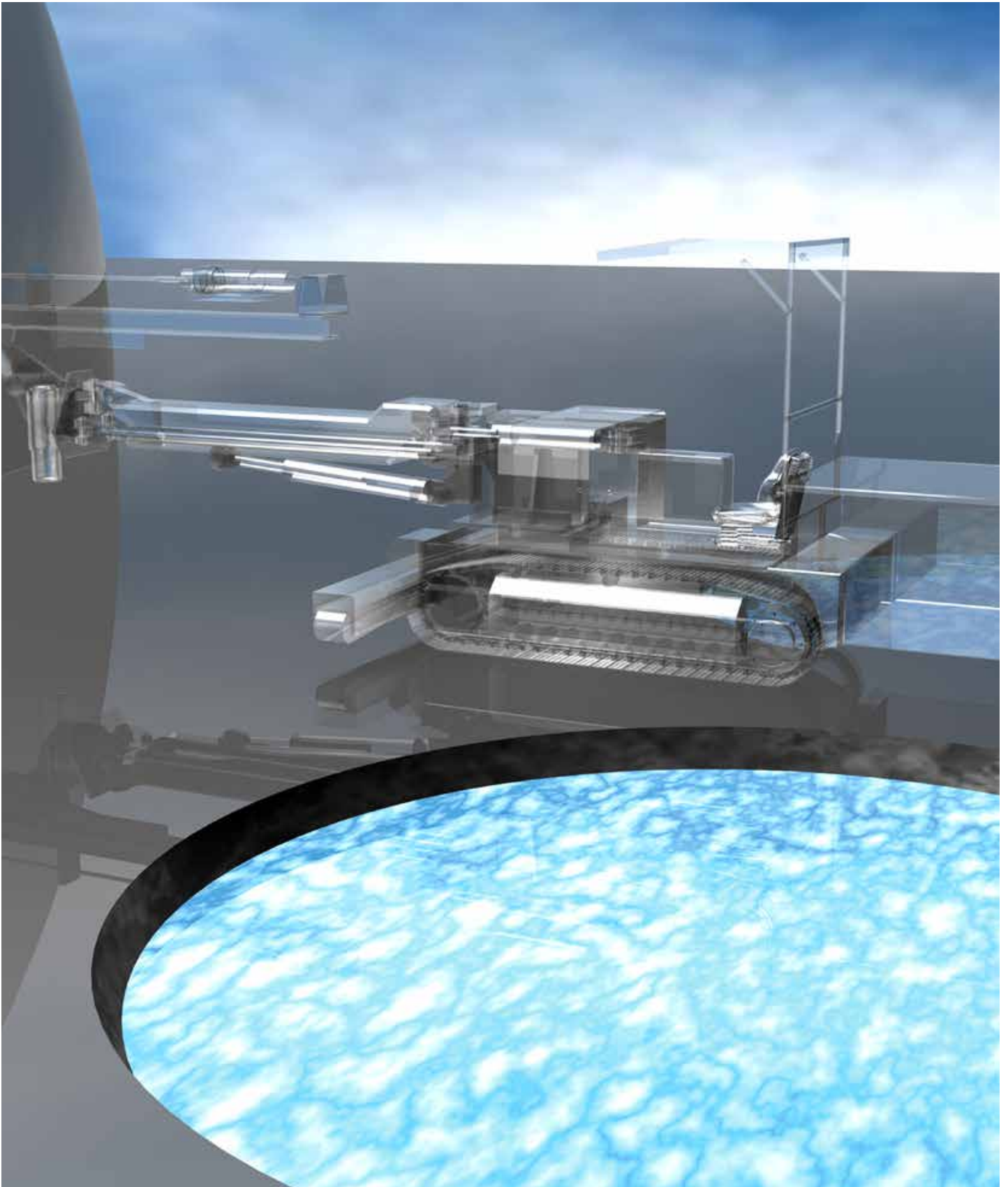



Our cartridge valve range includes screw-in cartridges with UNF or metric threads as well as plug-in and SAE standard valves.

They are characterised by their compact design, great reliability and low maintenance. Due to the many different possible combinations these valves can be universally used for directional, pressure, flow-control and check purposes. Our range of seat valves offers considerable advantages which ensure leakage-free applications.

Cartridge Valves

- **Solenoid Directional Valves**
Screw-in and ready to go
- **Pressure Valves**
Bypass and inline functions
- **Solenoid Valves**
We can take the pressure
- **Flow-control Valves**
For regulating flow volumes
- **Check Valves**
Small and safe



Screw-in and ready to go

Solenoid Directional Cartridge Valves



Features

- Available either with UNF or metric threads
- Seat valves
- Spool valves
- Also available with an emergency override

Advantages

- Small installation size
- Rotatable solenoid
- Solenoid can be replaced without contact with fluids

Size		3	5	10	16
Max. operating pressure	bar	420	420	350	420
Max. flow rate	l/min	15	40	140	350
Viscosity range	mm ² /s (cSt)	10 - 500			
Hydraulic fluid temperature	°C	-25 to +80			
Voltage	V	12, 24 DC / 115, 230 AC			
Type of actuation		Solenoid	Solenoid - Ex solenoid	Solenoid	Solenoid
Protection class		IP65 (EN 60 529) for solenoids · IP65/IP67 (EN 60 529) for Ex solenoids			
Size		3	5	10	16
Max. operating pressure	psi	6 000	6 000	5 000	6 000
Max. flow rate	gpm	4	11	37	92
Viscosity range	cSt	10 - 500			
Hydraulic fluid temperature	°F	-13 to +176			
Voltage	V	12, 24 DC / 115, 230 AC			
Type of actuation		Solenoid	Solenoid - Ex solenoid	Solenoid	Solenoid
Protection class		IP65 (EN 60 529) for solenoids · IP65/IP67 (EN 60 529) for Ex solenoids			

Robust and efficient

Cooler-Bypass Thermostat Valves



Features

- Temperature-dependent bypass control
- Integrated pressure relief function
- Various response temperatures and pressure settings
- Can be fitted in a line-mounting housing



Advantages

- Cooling circuit rapidly reaches its optimum operating temperature
- Can be installed directly into the cooler or line-mounting housing
- High functional reliability and stability
- Pressure safeguard to protect the cooler (peak pressures)
- Great durability without the necessity for complex maintenance work

Size		10	16		10	16
Max. operating pressure	bar	50	50	psi	700	700
Max. flow rate	l/min	120	300	gpm	32	79
Viscosity range	mm ² /s	10 - 650	10 - 650	cSt	10 - 650	10 - 650
Hydraulic fluid temperature	°C	-25 to +100	-25 to +80	°F	-13 to +212	-13 to +176
Type of actuation		Temperature-controlled				

Bypass and inline applications

Pressure Cartridge Valves



Features

- Directly and pilot controlled
- Pressure relief valves
- Pressure reducing valves
- Pressure compensator valves
- Pressure unloading valves
- For bypass and inline applications
- Logic valves

Advantages

- Small installation size
- Excellent characteristics
- Leak-proof

Size		3	4	10	16
Max. operating pressure	bar	315	420	450	420
Max. flow rate	l/min	12	30	140	350
Viscosity range	mm ² /s (cSt)	10 - 650	10 - 650	10 - 650	10 - 650
Hydraulic fluid temperature	°C	-25 to +80	-25 to +80	-25 to +80	-25 to +80
Size		3	4	10	16
Max. operating pressure	psi	4 500	6 000	6 400	6 000
Max. flow rate	gpm	3	8	37	92
Viscosity range	cSt	10 - 650	10 - 650	10 - 650	10 - 650
Hydraulic fluid temperature	°F	-13 to +176	-13 to +176	-13 to +176	-13 to +176

High power density

Pressure-Relief Cartridges



Features

- Protects pumps and/or actuators as well as the system against excess pressure
- Various pressure ranges
- Direct acting, cartridge-type seat valve

Advantages

- Hardened seat and poppet
- Leak-free
- Compact design means small space requirements

Model		UVP	DVP	DDP	DDP
Size		4	20	16D/E	32D/E
Max. operating pressure	bar	500	450	480	480
Max. flow rate	l/min	20	330	400	800
Adjustment range	bar	max. 500	max. 450	max. 480	max. 480
Viscosity range	mm ² /s	10 - 380	10 - 380	10 - 380	10 - 380
Hydraulic fluid temperature	°C	-20 to +80	-20 to +80	-20 to +80	-20 to +80
Model		UVP	DVP	DDP	DDP
Size		4	20	16D/E	32D/E
Max. operating pressure	psi	7 100	6 400	6 830	6 830
Max. flow rate	gpm	5.3	87	105	210
Adjustment range	psi	max. 7 100	max. 6 400	max. 6 830	max. 6 830
Viscosity range	cSt	10 - 380	10 - 380	10 - 380	10 - 380
Hydraulic fluid temperature	°F	-4 to +176	-4 to +176	-4 to +176	-4 to +176

Compact - long-lived - practical

Rapid Traverse Valves



Features

- Compact cartridge valve for implementing regenerative circuits in one cartridge
- No external pilot signal is required

Advantages

- Just one cartridge for 4 functions:
Hold, rapid traverse, work speed and return
- Compact design means small space requirements
- Works automatically, does not need any external switching signal, pressure switch, etc.

Model		EGP	
Size		20	25
Max. operating pressure	bar	350	350
Max. flow rate	l/min	250	400
Viscosity range	mm ² /s	15 - 250	
Hydraulic fluid temperature	°C	-20 bis +80	

Model		EGP	
Size		20	25
Max. operating pressure	psi	5 000	5 000
Max. flow rate	gpm	66	105
Viscosity range	cSt	10 - 250	
Hydraulic fluid temperature	°F	-4 to +176	

We can take the pressure

Solenoid Pressure Cartridge Valves



Features

- Directly and pilot controlled
- Pressure relief valves
- Pressure reducing valves
- Pressure compensator valves
- External pilot connection
- 2 pressure settings
- Proportional or on/off solenoids

Advantages

- Small installation size
- One valve - continuously variable pressures
- 2 pressure settings

Size		3	5	10	16
Max. operating pressure	bar	420	315	315	420
Max. flow rate	l/min	20	60	120	350
Viscosity range	mm ² /s (cSt)	10 - 500			
Hydraulic fluid temperature	°C	-25 to +80			
Type of actuation		Proportional or on/off solenoid			
Voltage	V	12, 24 DC / 115, 230 AC			
Protection class		IP65 (EN 60 529)			
Size		3	5	10	16
Max. operating pressure	psi	6 000	4 500	4 500	6 000
Max. flow rate	gpm	5.3	16	32	92
Viscosity range	cSt	10 - 500			
Hydraulic fluid temperature	°F	-13 to +176			
Type of actuation		Proportional or on/off solenoid			
Voltage	V	12, 24 DC / 115, 230 AC			
Protection class		IP65 (EN 60 529)			

For regulating flow volumes

Flow-Control Cartridge Valves



Features

- Directly and pilot controlled
- Seat and spool models available
- Throttle function
- Flow-control function
- Flow-control valve with pressure compensator spring adjustable
- Proportional or manual

Advantages

- Space-saving
- High quality
- Low pressure loss

Size		5	6	10	16
Max. operating pressure	bar	250	350	315	420
Max. flow rate	l/min	30	160	160	250
Viscosity range	mm ² /s (cSt)	10 - 500			
Hydraulic fluid temperature	°C	-25 to +80			
Type of actuation		Proportional	Manual	Proportional or manual	Proportional or manual
Voltage	V	12, 24 DC			
Protection class		IP65 (EN 60 529)			
Size		5	6	10	16
Max. operating pressure	psi	3 600	5 000	4 500	6 000
Max. flow rate	gpm	8	42	42	66
Viscosity range	cSt	10 - 500			
Hydraulic fluid temperature	°F	-13 to +176			
Type of actuation		Proportional	Manual	Proportional or manual	Proportional or manual
Voltage	V	12, 24 DC			
Protection class		IP65 (EN 60 529)			

Small and safe

Check Valves Cartridge Design



Features

- Screw-in or plug-in fitting
- With the RKVC and RVC ranges the checked direction is changed by inverting the cartridge
- Ball and plate valves
- Simple throttle/check functions can be achieved in plate valves by means of orifices in the plate
- Also available with hydraulic pilot operation
- For line-mounting valves

Advantages

- Small installation size
- High sealing properties
- High dynamics

Model		RV/RK	RW	REP
Nominal sizes		04 - 40 / 1/8" - 1 1/2"	2.5	10 - 16
Max. operating pressure	bar	350	315	350
Max. flow rate	l/min	360	8	300
Opening pressure	bar	0.2 - 2	0.16 - 6	2
Hydraulic fluid temperature	°C	-30 to +80	-25 to +80	-25 to +80
Model		RV/RK	RW	REP
Nominal sizes		04 - 40 / 1/8" - 1 1/2"	2.5	10 - 16
Max. operating pressure	psi	5000	4500	5000
Max. flow rate	gpm	95	2.1	79
Opening pressure	psi	2.9 - 30	2.3 - 90	30
Hydraulic fluid temperature	°F	-22 to +176	-22 to +176	-22 to +176

We control flow rates

Counterbalance Check Valves Cartridge Design



Features

- Model provided with thread
- Ball version
- Can be used as a counterbalance valve
- Pipe-work installation version available on request

Advantages

- Small installation size
- High level of leak tightness
- Flat characteristic curve

Model		RVVE		RVVE
Nominal sizes		04 - 40 / 1/8" - 1 1/2"		04 - 40 / 1/8" - 1 1/2"
Max. operating pressure	bar	350	psi	5 000
Max. flow rate	l/min	360	gpm	95
Opening pressure	mm ² /s	4 - 12	cSt	4 - 12
Hydraulic fluid temperature	°C	-30 bis +80		°F
				-22 to +176

Always the right solution

ERV / DERV Pilot-Operated Leak-Free Check Valves



Features

- Two stage, spring-closed seat valve in cartridge design
- Holds the load without leakage in the locking position
- Pressurised working circuits can be shut-off

Advantages

- Pilot-operated check valve and pipe-rupture valve function integrated in one unit
- Suitable for retracting loaded stabiliser cylinders at two different speeds
- For stabiliser cylinders on mobile vehicles and similar applications up to 600 bar (8 600 psi)

Model		ERV	DERV		ERV	DERV
Size		8	8 / 10		8	8 / 10
Max. operating pressure	bar	450 (600)	350 (500)	psi	6 400 (8 600)	5 000 (7 200)
Max. flow rate	l/min	60	70 (100)	gpm	16	16 (26)
Viscosity range	mm ² /s	10 - 380	10 - 380	cSt	10 - 380	10 - 380
Hydraulic fluid temperature	°C	-20 bis +80	-20 bis +80	°F	-4 to +176	-4 to +176



Our stack valve programme offers items compliant with standards ISO 4401-02-01 NG4, ISO 4401-03-02 NG6, ISO 4401-05-04 NG10, ISO 4401-07-07 NG16, CETOP R35H 03, 05, 07, A6 as per DIN 24340, A10 as per DIN 24340, A16 as per DIN 24340, NFPA D03, D05 and D07.

On request we can supply customised units with innumerable operations linked in vertical and horizontal stacks.

Stack Valves

- **Solenoid Directional Valves**
Directly and pilot controlled
- **Pressure Valves**
Keeping high pressures under control
- **Check Valves**
Hardened seats
- **Flow-control Valves**
For precise flow volume regulation
- **Check Valves**
Safe and dynamic



Directly or pilot operated

Solenoid Directional Stack Valves



Features

- **Mounting Pattern:**
 - ISO 4401-02-01 NG4
 - ISO 4401-03-02 NG6
 - ISO 4401-05-04 NG10
 - ISO 4401-07-07 NG16
 - CETOP R35H 03, 05, 07
 - DIN 24340 A6
 - DIN 24340 A10
 - DIN 24340 A16
 - NFPA D03, D05 and D07
- Direct or pilot operated
- Normally open or normally closed
- Bypass check valve

Advantages

- Operating units designed for specific applications
- Standardised components
- Simple installation and dismantling

Size		6	10	16
Max. operating pressure	bar	350	350	350
Max. flow rate	l/min	140	140	300
Viscosity range	mm ² /s (cSt)	10 - 500	10 - 500	10 - 500
Hydraulic fluid temperature	°C	-25 to +80	-25 to +80	-25 to +80
Voltage	V	12, 24 DC / 115, 230 AC		
Type of actuation		Solenoid		
Protection class		IP65 (EN 60 529)		
Size		6	10	16
Max. operating pressure	psi	5 000	5 000	5 000
Max. flow rate	gpm	37	37	79
Viscosity range	cSt	10 - 500	10 - 500	10 - 500
Hydraulic fluid temperature	°F	-13 to +176	-13 to +176	-13 to +176
Voltage	V	12, 24 DC / 115, 230 AC		
Type of actuation		Solenoid		
Protection class		IP65 (EN 60 529)		

Keeping high pressures under control

Stack-Mounting Pressure Valves



Features

- **Mounting Patterns:**
 - ISO 4401-02-01 NG4
 - ISO 4401-03-02 NG6
 - ISO 4401-05-04 NG10
 - ISO 4401-07-07 NG16
 - CETOP R35H 03, 05, 07
 - DIN 24340 A6
 - DIN 24340 A10
 - DIN 24340 A16
 - NFPA D03, D05 and D07
- Units with pressure relief, pressure reducing and sequence functions
- Manually adjustable, on/off solenoid, Hi/Lo, proportional solenoid

Advantages

- A huge selection of standardised components
- Adjustable and lockable in use

Size		4	6	10	16
Max. operating pressure	bar	250	350	350	350
Max. flow rate	l/min	25	80	140	300
Viscosity range	mm ² /s (cSt)	10 - 650	10 - 650	10 - 650	10 - 650
Hydraulic fluid temperature	°C	-25 to +80	-25 to +80	-25 to +80	-25 to +80
Voltage	V	12, 24 DC / 115, 230 AC			
Type of actuation		Manually adjustable, solenoid, proportional solenoid			
Protection class		IP65 (EN 60 529)			
Size		4	6	10	16
Max. operating pressure	psi	3 600	5 000	5 000	5 000
Max. flow rate	gpm	6.6	21	37	79
Viscosity range	cSt	10 - 650	10 - 650	10 - 650	10 - 650
Hydraulic fluid temperature	°F	-13 to +176	-13 to +176	-13 to +176	-13 to +176
Voltage	V	12, 24 DC / 115, 230 AC			
Type of actuation		Manually adjustable, solenoid, proportional solenoid			
Protection class		IP65 (EN 60 529)			

Hardened seats

Stack-Mounting Check Valves



Features

- **Mounting Patterns:**
 - ISO 4401-02-01 NG4
 - ISO 4401-03-02 NG6
 - ISO 4401-05-04 NG10
 - ISO 4401-07-07 NG16
 - CETOP R35H 03, 05, 07
 - DIN 24340 A6
 - DIN 24340 A10
 - DIN 24340 A16
 - NFPA D03, D05 and D07
- Check Valve
- Check valve also available with hydraulic pilot operation
- Direct or pilot operated

Advantages

- Compact design
- Standardised components
- Leak proof

Size		4	6	10	16
Max. operating pressure	bar	250	350	350	350
Max. flow rate	l/min	25	80	140	300
Viscosity range	mm ² /s (cSt)	10 - 650	10 - 650	10 - 650	10 - 650
Hydraulic fluid temperature	°C	-25 to +80	-25 to +80	-25 to +80	-25 to +80
Size		4	6	10	16
Max. operating pressure	psi	3 600	5 000	5 000	5 000
Max. flow rate	gpm	6.6	21	37	79
Viscosity range	cSt	10 - 650	10 - 650	10 - 650	10 - 650
Hydraulic fluid temperature	°F	-13 to +176	-13 to +176	-13 to +176	-13 to +176

For precise flow regulation

Stack-Mounting Flow Control Valves



Features

- Hole Patterns:
 - ISO 4401-02-01 NG4
 - ISO 4401-03-02 NG6
 - ISO 4401-05-04 NG10
 - ISO 4401-07-07 NG16
 - CETOP R35H 03, 05, 07
 - DIN 24340 A6
 - DIN 24340 A10
 - DIN 24340 A16
 - NFPA D03, D05 and D07
- Simple throttle function
- With bypass check valve
- Two-way flow controller

Advantages

- Economical components and installation
- Standardised components
- All settings can be locked

Size		4	6	10	16
Max. operating pressure	bar	250	350	350	350
Max. flow rate	l/min	25	80	160	260
Viscosity range	mm ² /s (cSt)	10 - 650	10 - 650	10 - 650	10 - 650
Hydraulic fluid temperature	°C	-25 to +80	-25 to +80	-25 to +80	-25 to +80
Size		4	6	10	16
Max. operating pressure	psi	3 600	5 000	5 000	5 000
Max. flow rate	gpm	6.6	21	42	69
Viscosity range	cSt	10 - 650	10 - 650	10 - 650	10 - 650
Hydraulic fluid temperature	°F	-13 to +176	-13 to +176	-13 to +176	-13 to +176

Safe and dynamic

Check Valves for SAE Flange Connections



Features

- Fit between port and flange
- Checked direction can be changed by inverting the valve
- Optionally available: Throttle function in checked direction
- Accessories: seal plates and insert plates

Advantages

- Compact design
- Great sealing properties
- High dynamics
- Same valve body for 3 000 psi and 6 000 psi mounting pattern

Model		RVSAE		RVSAE
Nominal Sizes		3/4" - 2 1/2"		3/4" - 2 1/2"
Max. operating pressure	bar	420	psi	6 000
Max. flow rate	l/min	Up to 1200	gpm	Up to 317
Opening pressure	bar	0.2 - 4	psi	3 - 60
Hydraulic fluid temperature	°C	-30 to +80	°F	-22 to +176





Thanks to their extensive experience in the field of practical applications, Bucher Hydraulics are in a position to offer an extensive programme of special valves for mobile and stationary uses.

Whenever heavy loads have to be moved or held it is essential to ensure first and foremost that all applicable safety regulations are adhered to. The following pages contain just a few examples from the range of valves which meet these exacting standards.

Safety Valves

- **Special Valves**
Always the right solution
- **Leak-Free Load Control Valves**
Controlling loads safely
- **Pipe Rupture Valves**
No uncontrolled movement

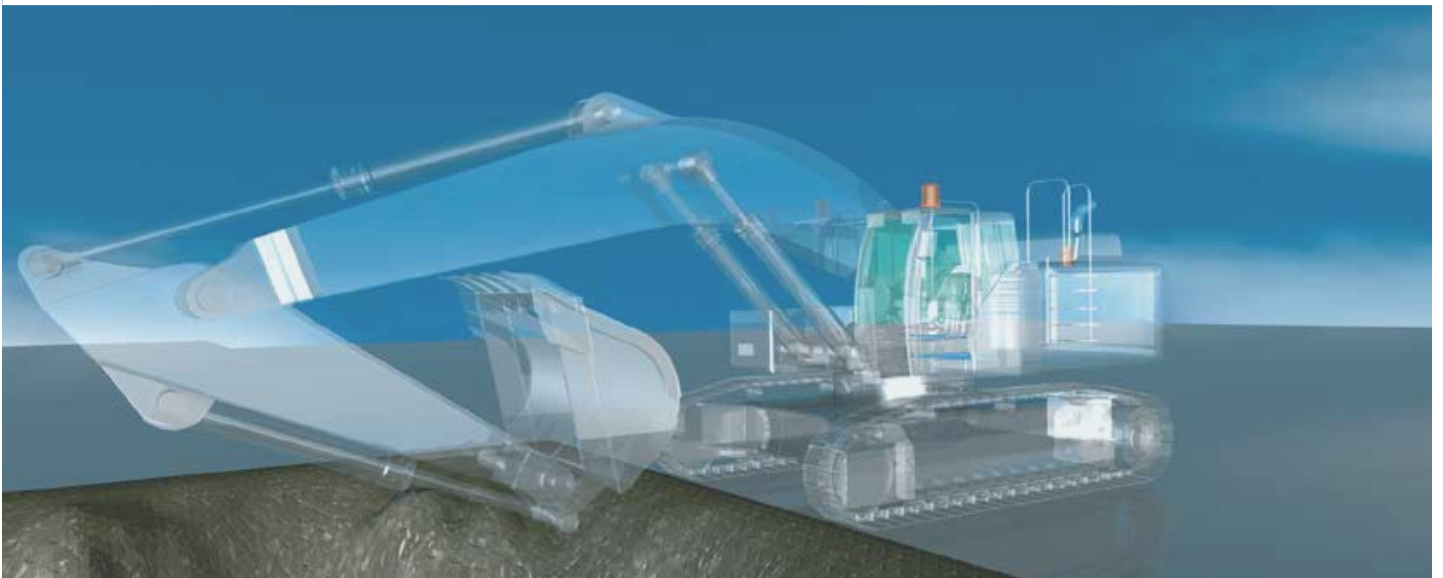

Always the right solution

Travel Brake Valves



Features

- FBVGA Double Travel Brake Valves
- WV03 Directional Valve

Advantages

- Valves comply with relevant safety regulations
- Designed specifically for particular applications
- Greatest possible safety

Model		FBVGA	WV03		FBVGA	WV03
Max. operating pressure	bar	420	315	psi	6 000	4 500
Max. flow rate	l/min	400	12	gpm	105	3,1
Viscosity range	mm ² /s (cSt)	10 - 380	10 - 300	cSt	10 - 380	10 - 300
Hydraulic fluid temperature	°C	-20 to +80	-20 to +80	°F	-4 to +176	-4 to +176

Superior control in a compact design

CINDY Leak-Free Load Control Valves

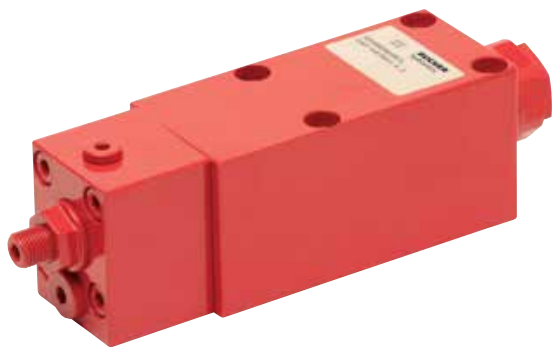

Features

- SAE flange, block and cartridge designs
- Block-mounted valve with integral secondary pressure relief valve
- Pilot operated
- Available with load pressure over-compensation

Advantages

- Valve locks even if the spring breaks
- Load-control, check and pipe rupture valve functions all incorporated in a single valve axis
- Great durability due to leak-free valve seat parts
- Greatest possible protection against unintentional movement

Model		CINDY SAE / CINDY manifold-mounting				CINDY cartridge	
Size		12	16	20	25	20	25
Max. operating pressure	bar	420	420	420	420	420	420
Secondary pressure	bar	460	460	460	460	460	460
Opening pressure	bar	Many different versions					
Max. flow rate	l/min	150	250	350	500	350	500
Viscosity range	mm ² /s	20 - 300					
Hydraulic fluid temperature	°C	-20 bis +80					
Model		CINDY SAE / CINDY manifold-mounting				CINDY cartridge	
Size		12	16	20	25	20	25
Max. operating pressure	psi	6 000	6 000	6 000	6 000	6 000	6 000
Secondary pressure	psi	6 540	6 540	6 540	6 540	6 540	6 540
Opening pressure	psi	Many different versions					
Max. flow rate	gpm	40	66	92	132	92	132
Viscosity range	cSt	20 - 300					
Hydraulic fluid temperature	°F	-4 bis +176					

Very high safety for large applications

CINDY-R Leak-Free Load Control Valves with Redundancy



Features

- Based on the tried-and-tested CINDY technology
- Two-stage operation
- Integral thermal-expansion pressure relief function

Advantages

- Redundant control assemblies in the valve mean increased safety for large-scale machines
- Compact design
- Extremely safe holding and lowering of loads
- Long service life

Model		CINDY-R		CINDY-R
Size		25		25
Max. operating pressure	bar	420	psi	6 000
Max. secondary pressure	bar	460	psi	6 540
Opening pressure		Many different versions		Many different versions
Max. flow rate	l/min	500	gpm	132
Viscosity range	mm ² /s	20 - 300	cSt	20 - 300
Hydraulic fluid temperature	°C	-20 to +80	°F	-4 to +176

Energy saving - the choice that secures the future

CINDY-REG Regenerative Leak-Free Load Control Valves



Features

- Potential energy stored in the cylinder is returned
- Based on the tried-and-tested CINDY technology
- Valve in body, with integral secondary pressure-relief valve
- Two-stage operation
- Various control covers for ideal matching with different control signals

Advantages

- No separate tank line is necessary
- Load-assisted closing function and high shut-off reliability
- Function is unaffected by load and return-line pressures

Model		CINDY-REG		CINDY-REG
Size		20		20
Max. operating pressure	bar	420	psi	6 000
Max. secondary pressure	bar	460	psi	6 540
Opening pressure		Many different versions		Many different versions
Max. flow rate	l/min	400	gpm	105
Viscosity range	mm ² /s	20 - 300	cSt	20 - 300
Hydraulic fluid temperature	°C	-20 to +80	°F	-4 to +176

Reliable, leak-free load holding

BBV Leak-Free Brake Valves



Features

- Prevents uncontrolled cylinder movement in the event of a hose- or pipe-rupture
- The integral, two-stage pressure-relief valve protects the work cylinder against excess pressure
- Also available as a cartridge valve

Advantages

- Leak-free load holding
- Thanks to the various pilot-control versions, the valve can be tailored to the system
- The control assembly is guaranteed to close, even with a broken spring
- Compact design means small space requirements

Model		BBV 6 (C)	BBV 6 (Standard)		BBV 6 (C)	BBV 6 (Standard)
Size		6	6		6	6
Max. operating pressure	bar	420	420	psi	6 000	6 000
Max. secondary pressure	bar	420	420	psi	6 000	6 000
Max. flow rate	l/min	50	50	gpm	13	13
Viscosity range	mm ² /s	10 - 380	10 - 380	cSt	10 - 380	10 - 380
Hydraulic fluid pressure	°C	-20 to +80	-20 to +80	°F	-4 to +176	-4 to +176

Lifting, lowering, load control

REFUVA Load Control Valves



Features

- For flange installation
- 1/2", 3/4", 1" and 1 1/4" SAE
- With integrated secondary pressure limiter

Advantages

- Leak-free load control
- Optimum Δp values during lifting and lowering operations
- Suitable for retro-fitting
- No adjustment to the directional valve necessary

Size		25		25	
Max. operating pressure	bar	420	psi	6 000	
Opening pressure	bar	Many different versions		psi	Many different versions
Max. flow rate	l/min	300	gpm	79	
Viscosity range	mm ² /s (cSt)	15 - 380	cSt	15 - 380	
Hydraulic fluid pressure	°C	-25 to +80	°F	-13 to +176	

Fail-safe movement control

Pipe Rupture Valves for Excavators



Features

- Fulfil the requirements of DIN 24093, ISO 8643 and EN 474-5 standards for earth-moving machinery
- Direct attachment via SAE 6000 psi flange
- Compact design
- Pressure limiting valve independent of the return pressure
- Secondary pressure limiting with no additional tank line

Advantages

- Insignificant lowering pressures
- Greatest possible protection against unintentional movement
- Adjustable flow for lock activation
- No need to change any of the hydraulic adjustments already made to the equipment
- Leak-free load holding

Model		ESV16	ESV20	ESV25	CFS16	CFS20
Max. operating pressure	bar	420	420	420	420	420
Max. flow rate	l/min	250	350	500	250	350
Viscosity range	mm ² /s (cSt)	10 - 380	10 - 380	10 - 380	10 - 380	10 - 380
Hydraulic fluid temperature	°C	-20 to +80	-20 to +80	-20 to +80	-20 to +80	-20 to +80

Model		ESV16	ESV20	ESV25	CFS16	CFS20
Max. operating pressure	psi	6 000	6 000	6 000	6 000	6 000
Max. flow rate	gpm	66	92	132	66	92
Viscosity range	cSt	10 - 380	10 - 380	10 - 380	10 - 380	10 - 380
Hydraulic fluid temperature	°F	-4 to +176	-4 to +176	-4 to +176	-4 to +176	-4 to +176

No uncontrolled motion

RS Pipe Rupture Valves



Features

- Cartridge design
- Screw in cartridges for pipe connection
- Ball valve or poppet valve

Advantages

- Very little space required
- Flow rate easily adjusted
- Adjustable flow for lock activation
- Greatest possible protection against unintentional movement

Size		8	12	16	32
Max. operating pressure	bar	350	350	350	300
Max. flow rate	l/min	40	80	160	500
Viscosity range	mm ² /s (cSt)	20 - 380	20 - 380	20 - 380	20 - 380
Hydraulic fluid temperature	°C	-20 to +80	-20 to +80	-20 to +80	-20 to +80

Size		8	12	16	32
Max. operating pressure	psi	5 000	5 000	5 000	4 300
Max. flow rate	gpm	11	21	42	130
Viscosity range	cSt	20 - 380	20 - 380	20 - 380	20 - 380
Hydraulic fluid temperature	°F	-4 to +176	-4 to +176	-4 to +176	-4 to +176



On 1st July, 2003 the European Parliament issued new directives concerning minimum levels required to improve the health and safety protection of workers who could be endangered by potentially explosive atmospheric conditions.

Since that date any products brought into circulation must comply with these new directives. Bucher Hydraulics supplies compliant hydraulic components.

Explosion Protected Valves

- **Valves for Potentially Explosive Areas**
European explosion protection legislation
- **Proportional Directional Valve System incorporating an Explosion Protected Design**
Simple, safe and precise



European explosion protection legislation

Valves for Potentially Explosive Areas



Features

- Examples of applications:
 - In gaseous atmospheres, II 2 G
 - In dust atmospheres, II 2 D
- Solenoids:
 - Ex em II T4 enhanced safety / metal casting encapsulation
 - Ex d II C T4...T6 pressure resistant encapsulation
- W- type solenoid valves in block, cartridge or pipework design
- Directly and pilot controlled

Advantages

- Compliant with ATEX safety requirements
- EC Type Approval Certification
- Rugged construction

Model		EEx-WED	EEx-WEV	EEx-W1
Nominal size		6	6 + 10	6
Max. operating pressure	bar	180	315	315
Max. flow rate	l/min	18	60 - 90	20
Viscosity range	mm ² /s (cSt)	10 - 500	10 - 500	10 - 500
Hydraulic fluid temperature	°C	-25 to +80	-25 to +80	-
Voltage	V	24 DC / 115, 230 AC	24 DC / 115, 230 AC	24 DC / 230 AC
Protection class		IP65/IP67 (EN 60 529)		
Model		EEx-WED	EEx-WEV	EEx-W1
Nominal size		6	6 + 10	6
Max. operating pressure	psi	2 600	4 500	4 500
Max. flow rate	gpm	4.8	16 - 24	5.3
Viscosity range	cSt	10 - 500	10 - 500	10 - 500
Hydraulic fluid temperature	°F	-13 to +176	-13 to +176	-
Voltage	V	24 DC / 115, 230 AC		
Protection class		IP65/IP67 (EN 60 529)		

Simple, safe and precise

Proportional Directional Valves Incorporating an Explosion Protected Design

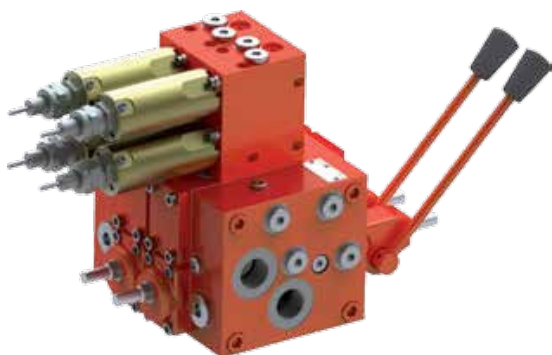

Features

- Explosion protected controls (e.g. for off-shore applications)
- Intrinsically safe controls for mining operations
- Several ranges available (CV, MV, SV, SC, SVC)
- Pilot valves with following ATEX certifications available:
 - CE0035 ⚠ I M2 Ex mb I
 - CE0035 ⚠ II 2G Ex mb II T4
 - CE0035 ⚠ II 2D Ex mbD 21 T130°C

Advantages

- Use of precise electrical proportional controls in areas where it has previously only been possible to install manually or hydraulically operated valves
- Electrically proportional or on/off controls in areas requiring a high level of protection

Size		12	16	SC18	SC22	SVC25
Max. operating pressure	bar	350	350	350	350	350
Max. return pressure	bar	50	50	50	50	50
Max. flow rate	l/min	100	200	260	400	600
Viscosity range	mm ² /s (cSt)	10 - 380				
Hydraulic fluid temperature	°C	-20 to +80				
Voltage	V	12 or 24 DC				
Type of actuation		Also in combination with manual or hydraulic actuation				
Size		12	16	SC18	SC22	SVC25
Max. operating pressure	psi	5 000	5 000	5 000	5 000	5 000
Max. return pressure	psi	700	700	700	700	700
Max. flow rate	gpm	26	53	69	105	158
Viscosity range	cSt	10 - 380				
Hydraulic fluid temperature	°F	-4 to +176				
Voltage	V	12 or 24 DC				
Type of actuation		Also in combination with manual or hydraulic actuation				



These lightweight aluminium valves are suitable for controlling single or double acting actuators. They are particularly suited to applications which demand a high degree of leak tightness. They are directly controlled 2/2 bi-directional seat valves which are solenoid operated. Their purpose is to control the feed and return pipes on hydraulic equipment with virtually zero leakage.

Directional Seat Valves

- **Seat Valves**
Zero leakage
- **Directional Seat Valves**
Lightweight and space-saving



Virtually zero leakage

SVH04 Seat Valves



Features

- Monoblock design with add-on sections
- Sectional construction allows for customised valve blocks
- Emergency override
- Integrated pressure limiter is optionally available
- Can be combined with other directional valve ranges

Advantages

- Economic alternative to conventional designs
- Minimal dimensions
- Leak-free sealing

Model		SVH04		SVH04
Max. operating pressure	bar	250	psi	3 600
Max. flow rate	l/min	20	gpm	5.3
Max. flow rates ports A and B	l/min	20	gpm	5.3
Viscosity range	mm ² /s (cSt)	10 - 300	cSt	10 - 300
Hydraulic fluid temperature	°C	-20 to +80	°F	-4 to +176
Voltage	V	12 or 24 DC	V	12 or 24 DC
Power consumption	W	27	hp	0.036
Type of actuation		Direct solenoid operation		

Lightweight and space-saving

WSH03 Directional Seat Valves



Features

- Monoblock design
- Lightweight aluminium construction
- 3/2 directional spool valve followed by a 2/2 directional seat valve
- Integrated manual override
- Pressure limiters and flow valves also available as options

Advantages

- Extremely space-saving
- Lightweight
- Leak-free sealing of feed and return pipes on hydraulic equipment

Model		WSH03		WSH03
Max. operating pressure	bar	250	psi	3 600
Max. flow rate	l/min	25	gpm	6.6
Max. flow rates ports A and B	l/min	25	gpm	6.6
Viscosity range	mm ² /s (cSt)	10 - 300	cSt	10 - 300
Hydraulic fluid temperature	°C	-20 to +80	°F	-4 to +176
Voltage	V	12 or 24 DC	V	12 or 24 DC
Power consumption	W	27	hp	0.036
Type of actuation		Direct solenoid operation		



Flow dividers and flow control valves are frequently used in mobile utility vehicles and stationary plant. Depending on the requirements involved, there are many different designs and additional functional features such as pressure relief valves, bypass valves, lock valves and shock valves.

Differential lock valves have been developed specifically for applications in hydrostatic drives with hydraulic motors connected in parallel, in open and closed loop systems.

Flow Valves

- **Flow Dividers**
for precise flow rate division
- **Flow Control Valves**
precise, safe and economical
- **Differential Lock Valves**
for locking transmissions professionally



For precise flow rate division

MTDA Flow Dividers

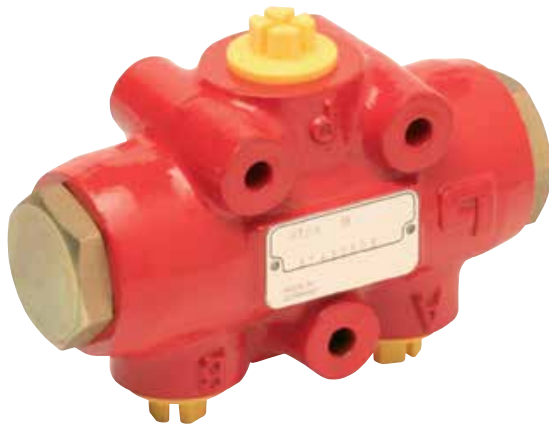

Features

- For installation in pipework
- Various division ratios
- **Versions:**
 - Flow dividers with very high division accuracy ($\pm 1.5\%$) (only for MTDA08)
 - High-pressure flow dividers up to 420 bar
- **Options:**
 - Final position adjustment
 - Anti-cavitation valve
 - Check valve
 - Pressure relief valve

Advantages

- Precise flow rate division and merging
- No maintenance required
- Heavy-duty and reliable
- Also available with zinc-nickel coating

Model		MTDA08	MTDA16		MTDA08	MTDA16
Max. operating pressure	bar	315 / 420		psi	4 500 / 6 000	
Flow range Q_m	l/min	2 - 100	35 - 250	gpm	0.5 - 26	9 - 66
Control accuracy	%	$\pm 3 / \pm 1,5$	± 3	%	$\pm 3 / \pm 1,5$	± 3
Viscosity range	mm ² /s (cSt)	10 - 300		cSt	10 - 300	
Hydraulic fluid temperature	°C	-20 bis +80		°F	-4 to +176	

Precise, safe and economical

Flow Control Valves



Features

- For installation in pipework
- Manually adjusted
- Surplus flow can be pressurised (MTKA, MTCA)
- Total flow protected by pressure relief valve (MTQA and MTCA)
- These flow-control valves are also available in a sectional design (MTKK and MTKL)

Advantages

- Control flow rates economically
- No maintenance required
- Just one turn of the adjuster for the entire control range

Model		MTKA	MTQA	MTCA
Max. operating pressure	bar	315	315	315
Max. flow rate	l/min	70	70	80
Adjustment range, variable	l/min		0 - 65	
Fixed adjustment range	l/min		3 - 60	
Viscosity range	mm ² /s (cSt)		10 - 300	
Hydraulic fluid temperature	°C		-20 to +80	
Model		MTKA	MTQA	MTCA
Max. operating pressure	psi	4 500	4 500	4 500
Max. flow rate	gpm	19	19	21
Adjustment range, variable	gpm		0 - 17	
Fixed adjustment range	gpm		0.8 - 16	
Viscosity range	cSt		10 - 300	
Hydraulic fluid temperature	°F		-4 to +176	

Load-independent flow control

Flow Control Valves



Features

- Configurations:
 - Cartridge design
 - Pipe-work installation type SRR
 - Motor/pump assembly
 - Valve manifold solutions with various additional operations
- 2 and 3 way modes
- Residual flow is resistant to compressive stress

Advantages

- Constant performance under varying temperature and load conditions
- No maintenance necessary
- Sturdy, simple, safe in operation
- Easy coil change, without disturbing fluid area
- Distinctive fine-adjustment range

Model		MVRPLSA	SRR	SRCB	SRCA
Max. operating pressure	bar	250	315	315	250
Max. flow rate	l/min	25	100	100	60
Constant flow range	l/min	20	0 - 80	0 - 80	0 - 50
Power consumption	W	19	27,6	27,6	16
Viscosity range	mm ² /s	15 - 380		10 - 300	
Hydraulic fluid temperature	°C	-25 bis +70		-20 bis +80	
Voltage	V	12 oder 24 DC		12 oder 24 DC	
Type of actuation		Proportional solenoid		Hand-wheel, firmly adjusted, proportional solenoid	
Max. operating pressure	psi	3600	4500	4500	3600
Max. flow rate	gpm	6.6	26	26	16
Constant flow range	gpm	5.3	0 - 21	0 - 21	0 - 13
Power consumption	hp	0.025	0.037	0.037	0.021
Viscosity range	cSt	15 - 380		10 - 300	
Hydraulic fluid temperature	°F	-13 to +158		-4 to +176	
Voltage	V	12 or 24 DC		12 or 24 DC	
Type of actuation		Proportional solenoid		Hand-wheel, firmly adjusted, proportional solenoid	

Lock transmissions professionally

MTxDV Differential Lock Valves



Features

- Valve manifold solutions optimized to suit installation positions
- Optionally available with threaded connections or SAE flange attachments
- Balancing orifices for best possible performance
- Pressure relief, shock and anti-cavitation valves available as options
- For 2, 3 or 4 motors

Advantages

- Robust and reliable
- No maintenance required
- Reliable, uniform motion of the intended wheel-drives
- Energy-optimised over the whole flow range

Model		MT08DV	MT16DVD		MT08DV	MT16DVD
Max. operating pressure	bar	420	420	psi	6 000	6 000
Max. flow rate Q _{max}	l/min	100	250	gpm	26	66
Max. flow rate	l/min	25, 50, 75, 100	120, 160, 200, 250	gpm	6.6, 13, 20, 26	32, 42, 53, 66
Viscosity range	mm ² /s (cSt)	10 - 300		cSt	10 - 300	
Hydraulic fluid temperature	°C	-20 to +80		°F	-4 to +176	
Voltage	V	12 or 24 DC		V	12 or 24 DC	
Power consumption	W	18		hp	0.024	
Type of actuation		Electro-hydraulic pilot operation, hydraulic pilot operation				



We have designed mobile electronic components specifically for applications in mobile plant and machinery. Their reliability under temperature fluctuations, rough mechanical loadings and electromagnetic interference conditions has been proven by rigorous testing and they have stood the test of time in production applications.

CAN-Bus and GPS compatibility, programmability and customer-specific operating controls ensure their communication with other machine systems and their suitability for the application requirements.

Mobile Electronics

- **Joysticks**
Everything to hand
- **Controls**
Display the operational status
- **Amplifier and Control PCB's**
Always the right solution



Everything to hand

Joysticks



Features

- Suitable for finely-tuned control of driving and operating functions
- Internal sensors with non-contact position sensing
- Further special models available on request
- Various handgrip configurations, also with hand rests

Advantages

- Compact design with minimal installation dimensions
- Simple, fatigue-proof operation
- Great reliability

Model	FGE	FGE/JS4	FGE/JS3	FCE/ID	FCE/J6SAE/J5SAE
Function	Lever switch	Prop. signal source	Prop. signal source	Prop. signal source	Prop. signal source
Signal	On / Off	Prop. signal	Prop. signal	Prop. signal	Prop. signal
Application	On-off solenoid	Prop. solenoid	Prop. solenoid	CAN-Bus	CAN-Bus
Voltage	V	9 - 30 DC	4,75 - 15 DC	9 - 30 DC	9 - 30 DC
Protection class	IP33	IP45 / IP33	IP65	IP65	IP67

Display the operational status

Operating Controls



Features

Bucher Hydraulics offer a wide range of operating controls with displays, pushbuttons and switches in a multitude of designs.

- Either as stand-alone units or for installation in control panels
- Analogue or digital controls
- Also available microprocessor controlled with diagnostic capability, PC interface and GPS connection

Advantages

- Compact design with minimal installation dimensions
- Simple, fatigue-free operation
- Great reliability

Model	Proportional Amplifiers	Analogue Control Units	Digital Control Unit
Power outputs	1	1 - 4	1 - 4
Switched outputs	1 - 2	1 - 6	1 - 6
Application	Proportional solenoids	Proportional solenoids	CAN-Bus
Voltage	V	12 - 30 DC	
Protection class	IP33	IP45 / IP33	IP65

Always the right solution

Amplifier and Control PCB's



Features

- For controlling on-off and proportional solenoids
- With ramp function
- Command variables also as frequencies
- Programmable functions
- Analogue, digital signals
- Implementation of control circuits

Advantages

- Performance data tailor made for your particular application
- Perfectly tuned to hydraulics
- Suitable for many different system configurations

Model	Proportional Amplifiers	Analogue Control Units	Multi-functional Circuit Boards
Power outputs	1 - 4	1	1 - 5
Switched outputs	1 - 2	1	1 - 5
Variable Inputs	1 - 4	1 - 4	1 - 8
Application	Proportional solenoids	Prop. and on-off solenoids	Prop. and on-off solenoids
Voltage	V 12 - 30 DC	12 - 24 DC	12 - 30 DC



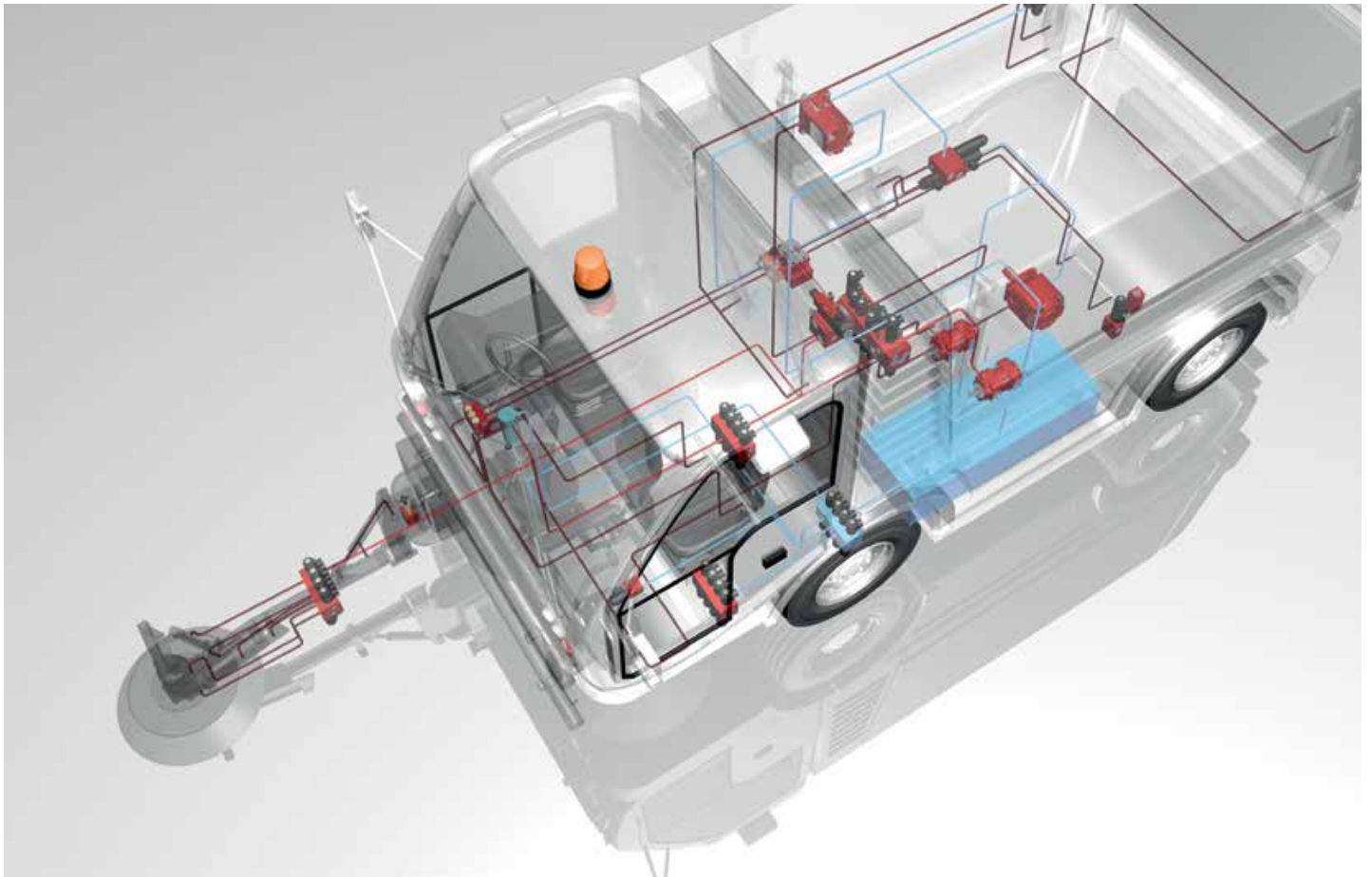

Our professional competence and the high performance reliability of Bucher Hydraulics' individual components have won worldwide recognition in the most varied of system solutions. We offer our customers valve manifolds and customized subsystems that can be used in a multitude of different application fields.

System Solutions

- System Solutions, Subsystems
- Fan Controls
- Internal Gear Units



Compact and energy efficient

System Solutions (Subsystems)

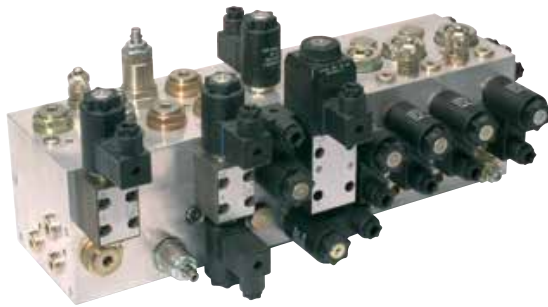

Features

- Valve manifolds available made of steel or aluminum
- Customized systems and components
- High degree of performance reliability and stability
- Customer oriented system solutions
- Optional with anti-corrosion treatment

Advantages

- Maximum performance in a minimum of space
- Reduced pipe-work and assembly costs
- 100 % performance tested
- High power density

Model		Aluminium	Steel		Aluminium	Steel
Valves fitted		NG3 - NG16	NG3 - NG16		NG3 - NG16	NG3 - NG16
Operating pressure	bar	210	420	psi	3 000	6 000
Max. flow rate	l/min	350		gpm	92	
Voltage	V	12, 24 DC / 115, 230 AC				
Protection category		IP65 compliant with EN 60529				
Connector plug types		DIN/EN, Junior Timer radial and axial, Deutsch, free cable heads				

Ideally matched with each other

Fan Controls and Blower Drives



Features

- Consist of pump/motor based on either external or internal gear principle, valve technology and control electronics
- Construction kit principle with options such as:
 - outrigger bearing for axial and radial power absorption
 - with anti-cavitation and pressure relief properties
 - with proportional or thermostatic valve technology

Advantages

- Cooling circuit rapidly brought up to operating temperature
- Recognition and control of up to 3 actual values
- Failsafe function
- Reversible
- Low Noise version (212LN) available: Pulsation -75 %

Model		AP/APR212	AP/APR212LN	APM/APMR212	APM/ APMR212LN	QXM
Displacement	cm ³ /rev	4.4 - 26.2	4.5 - 27.1	8.4 - 26.2	8.7 - 27.1	2.5 - 63
Max. continuous pressure (P1)	bar	170 - 250	170 - 250	200 - 250	200 - 250	210
Max. peak pressure (P3)	bar	220 - 300	220 - 300	210 - 300	210 - 300	250
Speed range	min ⁻¹	500 - 4 000	500 - 4 000	500 - 4 000	500 - 4 000	100 - 6 500
Hydraulic fluid temperature	°C	-15 to +80	-15 to +80	-15 to +80	-15 to +80	-25 to +80
Voltage	V	12 - 28 DC				

Model		AP/APR212	AP/APR212LN	APM/APMR212	APM/APMR212LN	QXM
Displacement	in ³ /rev	0.27 - 1.6	0.28 - 1.65	0.51 - 1.6	0.53 - 1.65	0.16 - 48
Max. continuous pressure (P1)	psi	2 400 - 3 600	2 400 - 3 600	2 900 - 3 600	2 900 - 3 600	3 000
Max. peak pressure (P3)	psi	3 100 - 4 300	3 100 - 4 300	3 000 - 4 300	3 000 - 4 300	3 600
Speed range	rpm	500 - 4 000	500 - 4 000	500 - 4 000	500 - 4 000	100 - 6 500
Hydraulic fluid temperature	°F	5 to +176	5 to +176	5 to +176	5 to +176	-13 to +176
Voltage	V	12 - 28 DC				

Only the flow rate that's needed

Internal Gear Pumps for Variable Speed Drives

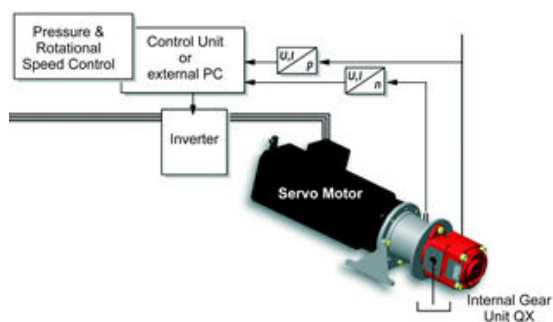

Features

- Continuously variable flow rate (0% to 100%)
- Dependent on the model, can be used in 1-, 2- or 4-quadrant operation
- Low inertias, high dynamic response
- Acceleration from 0 to 2750 rpm in 70 ms
- Fast payback of the investment

Advantages

- Energy savings of up to 70 %
- Noise reduction of 10 to 20 dB(A)
- Reduced oil volume
- Raises productivity levels

Size		QXE32	QXE42	QXE52	QXE62
Displacement	cm ³ /rev	10 - 15,6	20,4 - 32,4	39,3 - 63,7	80,2 - 160,2
Flow rate with 1450 min ⁻¹	l/min	14,5 - 22,6	29,5 - 46,8	56,9 - 92,1	116 - 232
Max. speed	min ⁻¹	3 800 - 4 600	3 400 - 4 000	2 800 - 3 200	2 300 - 2 700
Input power	kW	6,0 - 9,4	12,3 - 19,6	23,7 - 38,5	48,5 - 67,9
Torque	Nm	39,8 - 62,1	81,2 - 129	156,4 - 253,6	319,3 - 447

Size imperial		QXE32	QXE42	QXE52	QXE62
Displacement	in ³ /rev	0.6 - 1	1.2 - 2	2.4 - 3.9	4.9 - 9.8
Flow rate at 1450 rpm	gpm	0.4 - 6	7.8 - 12.4	15 - 24.3	30.6 - 61.3
Max. speed	rpm	3 800 - 4 600	3 400 - 4 000	2 800 - 3 200	2 300 - 2 700
Input power	kW	6,0 - 9,4	12,3 - 19,6	23,7 - 38,5	48,5 - 67,9
Torque	lbf ft	29.4 - 45.8	59.9 - 95.1	115.3 - 187	235.5 - 329.7



Up to 6 driver profiles can be parametrised and saved

System Solutions for Crane Controls



Features

- **System versions:**
 - Manual operation
 - Electro-hydraulic, two-stage
 - High end with on-board electronics
- **Application examples:**
 - Forestry cranes for skidders, forwarders, vehicle-mounted cranes, usw.
 - Material handlers
 - Truck-mounted cranes
- Mechanical changeover for systems supplied by fixed-displacement pumps or LS pumps

Advantages

- Parametrisation optimised for the driver
- "Plug and Play" system
- Sustained cost reductions and increases in performance ratings
- Precise and stable crane control
- Driver enjoys fatigue-free working
- Long service life even under extreme loads

System components

Proportional directional valve system	LVS	P_{max} 350 bar, Q_{max} 300 l/min, manual operation, electro-hydraulic two-stage, onboard electronics
Master board	ELMR224	116 - 232
Joystick	FCE	Various Joystick versions based on CANopen
Crane terminal	EBT450	Intelligent compact display used as the terminal for operation and parametrisation Up to 6 driver profiles can be parametrised and saved
System accessories		Wiring harness, connection cable, interconnecting cable, plug

EPOM (Externally Propelled Off-Highway Machines)

System Solutions for Towed Machines

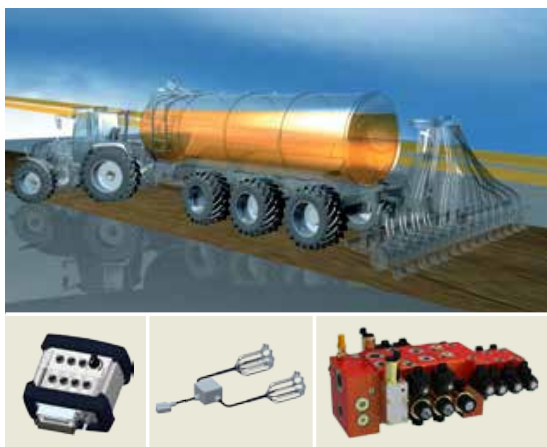

Features

- **System versions:**
 - Control unit and hydraulic control system with a maximum of 8 valve sections
 - Control unit and hydraulic control system with a maximum of 11 valve sections
- **Application examples:**
Towed machines in agriculture, such as slurry tankers, manure spreaders, self-loading feed wagons, feed-spreader wagons, usw.
- Component tank-line pressure ratings to 200 bar
- Complete steering systems with approval for on-road use can be integrated
- Valves for leak-free actuator functions can be integrated

Advantages

- Sustained cost reductions and increases in performance ratings
- Minimal headlosses
- Can be used with all pump systems
- Long service life even under extreme loads

System components

Proportional directional valve system	LVS	P_{max} 350 bar, Q_{max} 240 l/min, operation via solenoid, proportional solenoid, electro-hydraulic two-stage
Control unit	EBT-610	Heavy-duty control unit, developed for agricultural machinery, with 7 toggle switches and a rotary potentiometer
Control unit	EBT-620	Heavy-duty control unit, developed for agricultural machinery, with 8 toggle switches, a rotary potentiometer and a 4-way (North, S, E, W) toggle switch
Wiring harness	EBT-6	Interconnection between valve block and control unit.
Steering system		Electro-hydraulic steering systems with approval for on-road use



Bucher Hydraulics – At your service worldwide

Always a good address Our sales centers and distribution partners are particularly successful in finding solutions for you in conjunction with our Competence Centers in Europe, North America, South America and Asia. We offer you hydraulic systems, harmonized with your specific needs and requirements in all the different market places in mind.

Challenge us – around the globe!
www.bucherhydraulics.com/contact

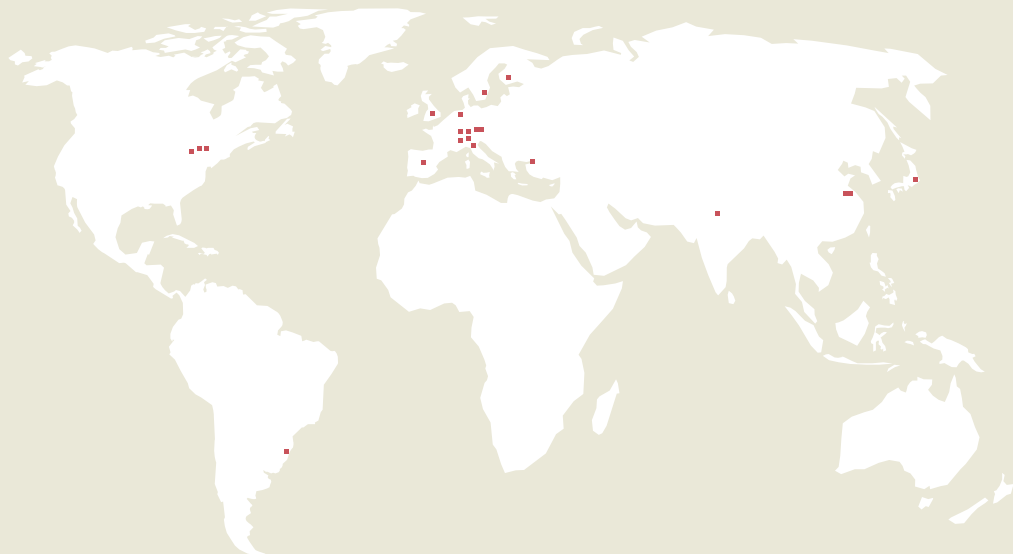

Smart Solutions.
Superior Support.

Bucher Hydraulics
info@bucherhydraulics.com

For further information visit us at:
www.bucherhydraulics.com